

ADR-A SERIES

- ▶ Direct drive brushless motor
- ▶ Fully integrated with encoder and bearing
- ▶ Low cogging torque
- ▶ Precise homing through index pulse
- ▶ Low and high speed windings are optional

EN-26.3.1

ADR110-A98

ADR110-A98				
Performance Parameters	Symbol	Unit	Series	Parallel
Continuous Torque @100°C ①	T _{cn}	Nm	4.2	4.2
Peak Torque	T _{pk}	Nm	11.3	11.3
Torque Constant ±10%	K _t	Nm/Arms	1.40	0.70
Back EMF constant ±10%	K _e	Vpeak/rpm	0.119	0.060
Motor Constant @25°C	K _m	Nm/Sqrt(W)	0.51	0.49
Resistance (L-L) @25°C ±10% ②	R ₂₅	Ω	4.90	1.37
Inductance (L-L) ±20% ③	L	mH	23.5	6.49
Electrical time constant	τ _e	ms	4.80	4.73
Continuous Current @100°C ①	I _{cn}	Arms	3.0	6.0
Peak Current	I _{pk}	Arms	9.0	18.0
Continuous Power Dissipation @100°C ①	P _{cn}	W	85.3	95.4
Max. Coil Temperature	T _{max}	°C	100.0	100.0
Thermal Dissipation Constant ①	K _{thn}	W/°C	1.1	1.3
Max. Bus Voltage	U _{bus}	Vdc	600.0	600.0
Pole Number	2P	-	16	16
Rec. Max Speed @Peak Torque ④	Ω _{max}	rpm	1600	2000
Rec. Max Speed @Continuous Torque ④	Ω _{max}	rpm	2000	2000
Mechanical Parameters				
Overall Mass	m _n	kg	4.60	4.60
Rotor Inertia	J _r	kg·m ²	4.419E-04	4.419E-04
Axial Runout ⑤	-	μm	15 (10,5)	15 (10,5)
Radial Runout ⑤	-	μm	15 (10,5)	15 (10,5)
Max Axial Load (Upright Mounting) ⑥	-	N	700	700
Max Axial Load (Inverted / Wall mounting)	-	N	150	150
Max Moment Load (Upright Mounting)	-	Nm	20	20
Max Moment Load (Inverted / Wall Mounting)	-	Nm	2.2	2.2
Encoder Parameters				
ABI Optical Incremental Encoder (SIN/COS)	-	lines / rev	3005	3005
ABI Optical Incremental Encoder Digital Resolution (80x)	-	counts / rev	240400	240400
ABI Optical Incremental Encoder Digital Resolution (160x)	-	counts / rev	480800	480800
ABI Optical Incremental Encoder Digital Resolution (400x)	-	counts / rev	1202000	1202000
ATOM DX Optical Incremental Encoder	-	lines / rev	5870	5870
ATOM DX Optical Incremental Encoder(80x)	-	counts / rev	469600	469600
Accuracy with Error Mapping ⑦	-	arc sec	+/-5.4	+/-5.4
Repeatability ⑦	-	arc sec	+/-2.7	+/-2.7
Other Information				
Insulation Class	Class B (130°C)			
Protection Grade	IP40			
Compliance with Global Standards	RoHS, CE, UL (option)			
Ambient Temperature	Operation	0°C to 40°C (non-freezing)		
	Storage	-15°C to 70°C (non-freezing)		
Ambient Humidity	Operation	10%RH to 80%RH (non-condensing)		
	Storage	10%RH to 90%RH (non-condensing)		
Recommended Ambience	Indoor (no direct sunlight); No corrosive gas, inflammable gas, oil mist or dust.			

- ① Measurement is taken at ambient temperature 25°C. Value depends on the thermal environment.
- ② Resistance is measured by DC current with standard 0.5m cable.
- ③ Inductance is measured by current frequency of 1kHz.
- ④ The value is based on ABI optical SIN/COS encoder (4096x interpolation) under 330V bus voltage.
- ⑤ Runout specification define in the datasheet is based on constant loading and temperature condition (the value in parenthesis is optional).
- ⑥ Please refer to the illustration for different mountings.
- ⑦ Based on ABI optical SIN/COS encoder (4096x interpolation) with standard runout. The contents of datasheet are subject to change without prior notice.

Dimension

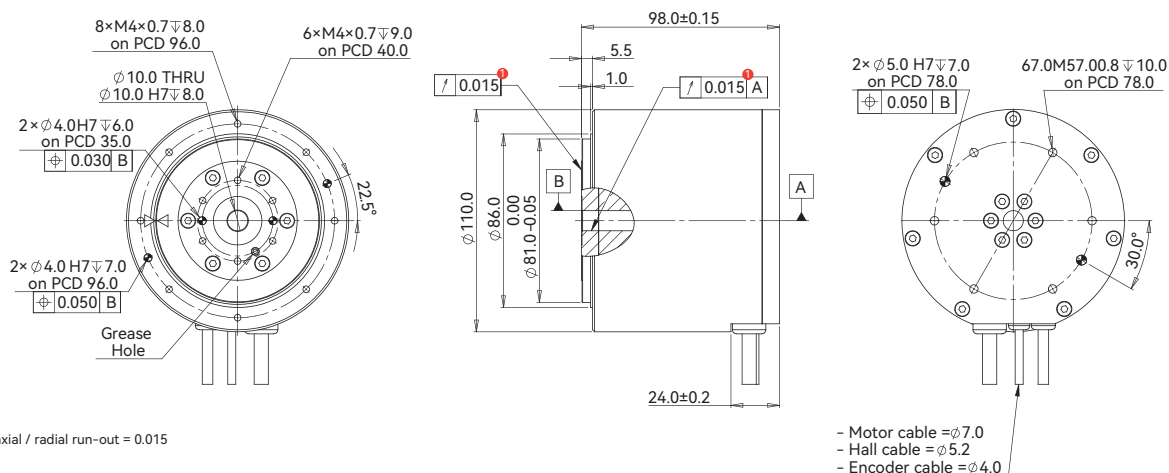

Torque-Speed Curve

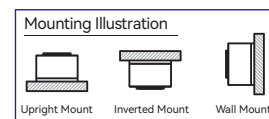
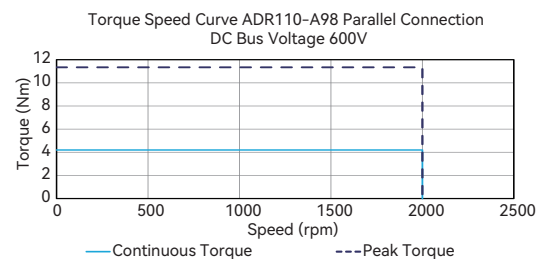
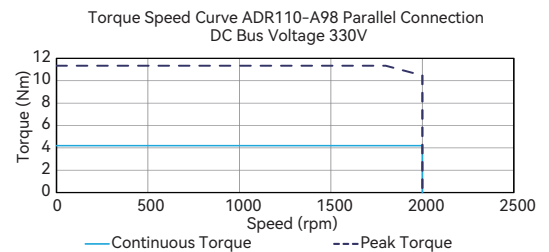
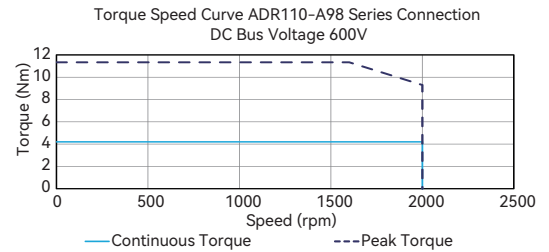
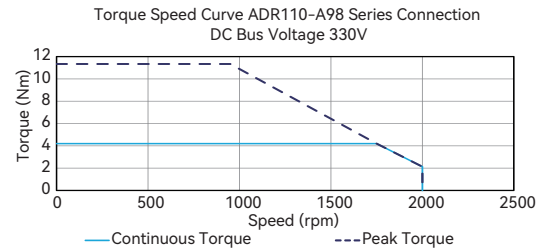

Introduction
Sizing Guide
Frequently Asked Questions
Linear Motors
Voice Coil Motors
Direct Drive Rotary Motors
Magnet Spring
Motion Control of Gantry Stages

ADR135-A90

ADR135-A90

Performance Parameters	Symbol	Unit	Series	Parallel
Continuous Torque @100°C ①	T _{cn}	Nm	5.3	5.3
Peak Torque	T _{pk}	Nm	14.3	14.3
Torque Constant ±10%	K _t	Nm/Arms	2.3	1.1
Back EMF constant ±10%	K _e	Vpeak/rpm	0.197	0.098
Motor Constant @25°C	K _m	Nm/Sqrt(W)	0.73	0.73
Resistance (L-L) @25°C ±10% ②	R ₂₅	Ω	6.60	1.65
Inductance (L-L) ±20% ③	L	mH	45.30	11.20
Electrical time constant	τ _e	ms	6.86	6.79
Continuous Current @100°C ①	I _{cn}	Arms	2.3	4.6
Peak Current	I _{pk}	Arms	6.9	13.8
Continuous Power Dissipation @100°C ①	P _{cn}	W	67.5	67.5
Max. Coil Temperature	T _{max}	°C	100.0	100.0
Thermal Dissipation Constant ①	K _{thn}	W/°C	0.9	0.9
Max. Bus Voltage	U _{bus}	Vdc	600.0	600.0
Pole Number	2P	-	16	16
Rec. Max Speed @Peak Torque ④	Ω _{max}	rpm	1050	1350
Rec. Max Speed @Continuous Torque ⑤	Ω _{max}	rpm	1350	1350

Mechanical Parameters				
Overall Mass	m _n	kg	4.80	4.80
Rotor Inertia	J _r	kg·m ²	9.916E-04	9.916E-04
Axial Runout ⑥	-	μm	15 (10,5)	15 (10,5)
Radial Runout ⑥	-	μm	15 (10,5)	15 (10,5)
Max Axial Load (Upright Mounting) ⑦	-	N	1050	1050
Max Axial Load (Inverted / Wall mounting)	-	N	180	180
Max Moment Load (Upright Mounting)	-	Nm	35	35
Max Moment Load (Inverted / Wall Mounting)	-	Nm	3.9	3.9

Encoder Parameters				
ABI Optical Incremental Encoder (SIN/COS)	-	lines / rev	3005	3005
ABI Optical Incremental Encoder Digital Resolution (80x)	-	counts / rev	240400	240400
ABI Optical Incremental Encoder Digital Resolution (160x)	-	counts / rev	480800	480800
ABI Optical Incremental Encoder Digital Resolution (400x)	-	counts / rev	1202000	1202000
ATOM DX Optical Incremental Encoder	-	lines / rev	5870	5870
ATOM DX Optical Incremental Encoder (80x)	-	counts / rev	469600	469600
Accuracy with Error Mapping ⑧	-	arc sec	+/-5.4	+/-5.4
Repeatability ⑨	-	arc sec	+/-2.7	+/-2.7

Other Information		
Insulation Class	Class B (130°C)	
Protection Grade	IP40	
Compliance with Global Standards	RoHS, CE, UL (option)	
Ambient Temperature	Operation	0°C to 40°C (non-freezing)
	Storage	-15°C to 70°C (non-freezing)
Ambient Humidity	Operation	10%RH to 80%RH (non-condensing)
	Storage	10%RH to 90%RH (non-condensing)
Recommended Ambience	Indoor (no direct sunlight); No corrosive gas, inflammable gas, oil mist or dust.	

- ① Measurement is taken at ambient temperature 25°C. Value depends on the thermal environment.
 - ② Resistance is measured by DC current with standard 0.5m cable.
 - ③ Inductance is measured by current frequency of 1kHz.
 - ④ The value is based on ABI optical SIN/COS encoder (4096x interpolation) under 330V bus voltage.
 - ⑤ Runout specification define in the datasheet is based on constant loading and temperature condition (the value in parenthesis is optional).
 - ⑥ Please refer to the illustration for different mountings.
 - ⑦ Based on ABI optical SIN/COS encoder (4096x interpolation) with standard runout.
- The contents of datasheet are subject to change without prior notice.

Dimension

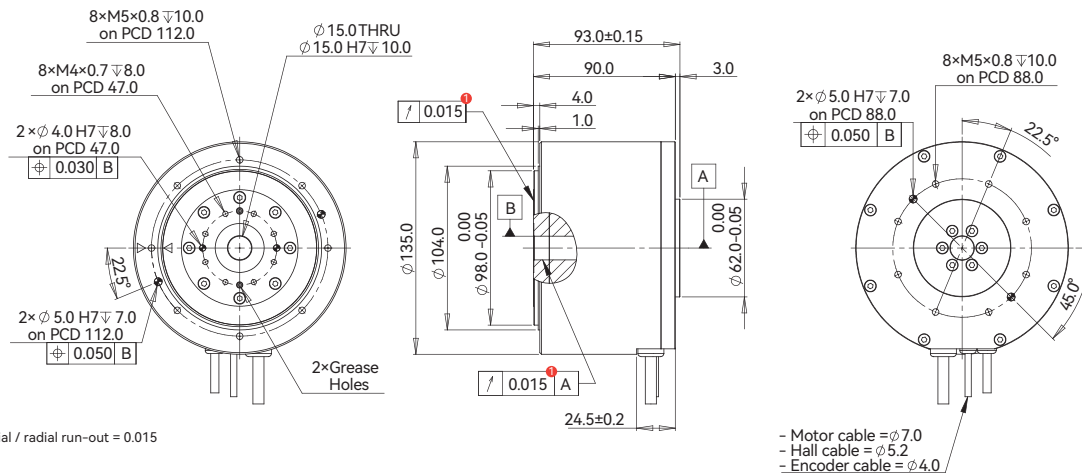

Torque-Speed Curve

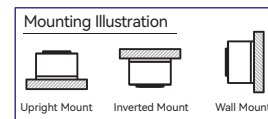
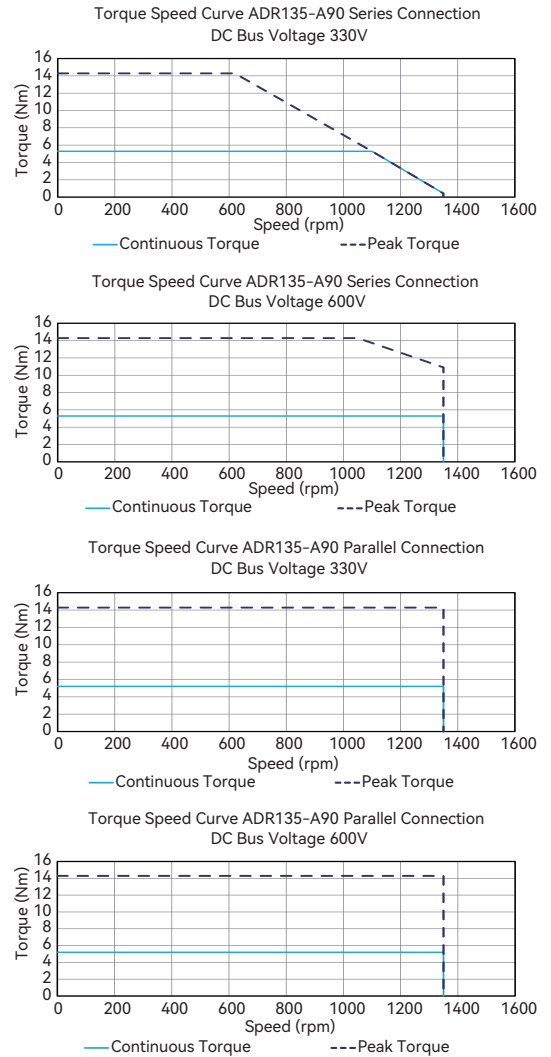

ADR135-A115

ADR135-A115				
Performance Parameters	Symbol	Unit	Series	Parallel
Continuous Torque @100°C ❶	T _{cn}	Nm	11.0	11.0
Peak Torque	T _{pk}	Nm	29.8	29.8
Torque Constant ±10%	K _t	Nm/Arms	4.8	2.4
Back EMF constant ±10%	K _e	Vpeak/rpm	0.41	0.21
Motor Constant @25°C	K _m	Nm/Sqrt(W)	1.2	1.2
Resistance (L-L) @25°C ±10% ❷	R ₂₅	Ω	10.70	2.70
Inductance (L-L) ±20% ❸	L	mH	72.76	18.63
Electrical time constant	τ _e	ms	6.80	6.90
Continuous Current @100°C ❶	I _{cn}	Arms	2.3	4.6
Peak Current	I _{pk}	Arms	6.9	13.8
Continuous Power Dissipation @100°C ❶	P _{cn}	W	109.4	110.5
Max. Coil Temperature	T _{max}	°C	100.0	100.0
Thermal Dissipation Constant ❶	K _{thn}	W/°C	1.5	1.5
Max. Bus Voltage	U _{bus}	Vdc	600.0	600.0
Pole Number	2P	-	16	16
Rec. Max Speed @Peak Torque ❹	Ω _{max}	rpm	550	745
Rec. Max Speed @Continuous Torque ❹	Ω _{max}	rpm	745	745
Mechanical Parameters				
Overall Mass	m _n	kg	4.90	4.90
Rotor Inertia	J _r	kg·m ²	1.332E-03	1.332E-03
Axial Runout ❺	-	μm	15 (10,5)	15 (10,5)
Radial Runout ❺	-	μm	15 (10,5)	15 (10,5)
Max Axial Load (Upright Mounting) ❻	-	N	1050	1050
Max Axial Load (Inverted / Wall mounting)	-	N	180	180
Max Moment Load (Upright Mounting)	-	Nm	35	35
Max Moment Load (Inverted / Wall Mounting)	-	Nm	3.9	3.9
Encoder Parameters				
ABI Optical Incremental Encoder (SIN/COS)	-	lines / rev	3005	3005
ABI Optical Incremental Encoder Digital Resolution (80x)	-	counts / rev	240400	240400
ABI Optical Incremental Encoder Digital Resolution (160x)	-	counts / rev	480800	480800
ABI Optical Incremental Encoder Digital Resolution (400x)	-	counts / rev	1202000	1202000
ATOM DX Optical Incremental Encoder	-	lines / rev	5870	5870
ATOM DX Optical Incremental Encoder (80x)	-	counts / rev	469600	469600
Accuracy with Error Mapping ❷	-	arc sec	+/-5.4	+/-5.4
Repeatability ❷	-	arc sec	+/-2.7	+/-2.7
Other Information				
Insulation Class	Class B (130°C)			
Protection Grade	IP40			
Compliance with Global Standards	RoHS, CE, UL (option)			
Ambient Temperature	Operation	0°C to 40°C (non-freezing)		
	Storage	-15°C to 70°C (non-freezing)		
Ambient Humidity	Operation	10%RH to 80%RH (non-condensing)		
	Storage	10%RH to 90%RH (non-condensing)		
Recommended Ambience	Indoor (no direct sunlight); No corrosive gas, inflammable gas, oil mist or dust.			

- ❶ Measurement is taken at ambient temperature 25°C. Value depends on the thermal environment.
 - ❷ Resistance is measured by DC current with standard 0.5m cable.
 - ❸ Inductance is measured by current frequency of 1kHz.
 - ❹ The value is based on ABI optical SIN/COS encoder (4096x interpolation) under 330V bus voltage.
 - ❺ Runout specification define in the datasheet is based on constant loading and temperature condition (the value in parenthesis is optional).
 - ❻ Please refer to the illustration for different mountings.
 - ❼ Based on ABI optical SIN/COS encoder (4096x interpolation) with standard runout.
- The contents of datasheet are subject to change without prior notice.

Dimension

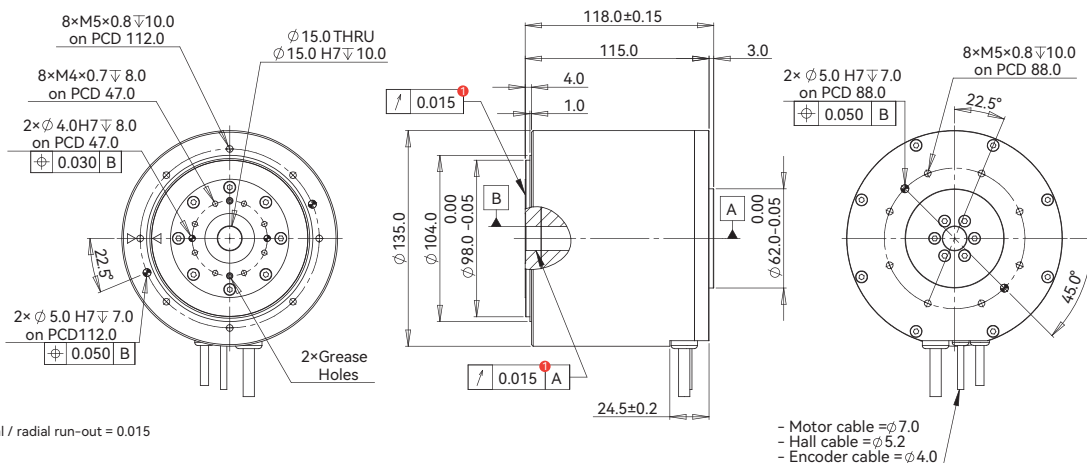

❶ Standard axial / radial run-out = 0.015

Torque-Speed Curve

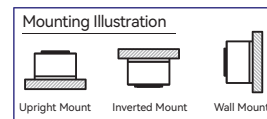
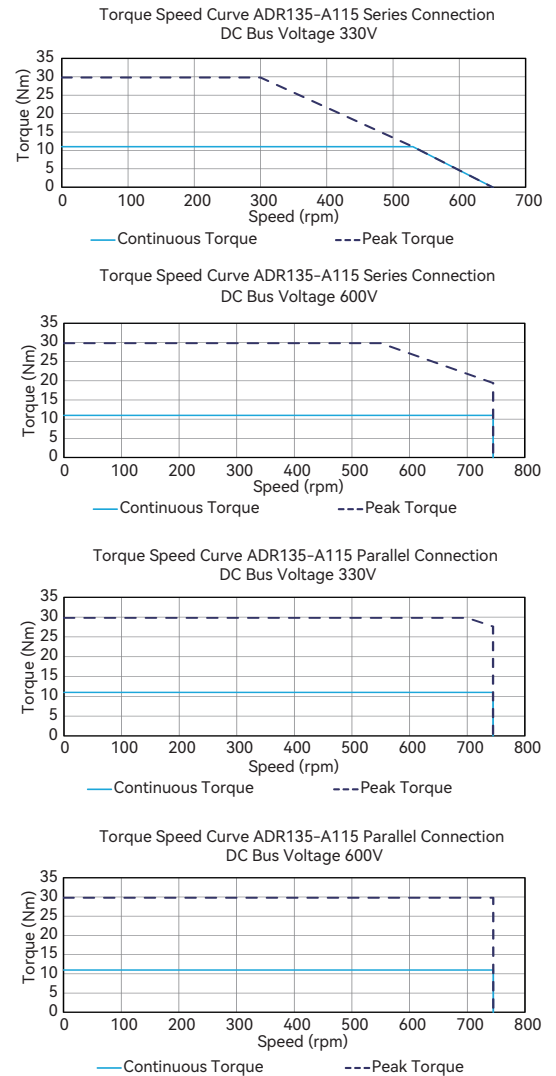

ADR175-A102

Introduction Sizing Guide Frequently Asked Questions Linear Motors Voice Coil Motors Direct Drive Rotary Motors Magnet Spring Motion Control of Gantry Stages

ADR175-A102				
Performance Parameters	Symbol	Unit	Series	Parallel
Continuous Torque @100°C ①	T _{cn}	Nm	16.0	16.0
Peak Torque	T _{pk}	Nm	43.2	43.2
Torque Constant ±10%	K _t	Nm/Arms	5.0	2.5
Back EMF constant ±10%	K _e	Vpeak/rpm	0.43	0.21
Motor Constant @25°C	K _m	Nm/Sqrt(W)	1.78	1.79
Resistance (L-L) @25°C ±10% ②	R ₂₅	Ω	5.27	1.30
Inductance (L-L) ±20% ③	L	mH	37.00	9.70
Electrical time constant	τ _e	ms	7.02	7.46
Continuous Current @100°C ①	I _{cn}	Arms	3.2	6.4
Peak Current	I _{pk}	Arms	9.6	19.2
Continuous Power Dissipation @100°C ①	P _{cn}	W	104.4	103.0
Max. Coil Temperature	T _{max}	°C	100.0	100.0
Thermal Dissipation Constant ①	K _{thn}	W/°C	1.4	1.4
Max. Bus Voltage	U _{bus}	Vdc	600.0	600.0
Pole Number	2P	-	16	16
Rec. Max Speed @Peak Torque ④	Ω _{max}	rpm	660	880
Rec. Max Speed @Continuous Torque ⑤	Ω _{max}	rpm	880	880
Mechanical Parameters				
Overall Mass	m _n	kg	8.5	8.5
Rotor Inertia	J _r	kg·m ²	5.422E-03	5.422E-03
Axial Runout ⑥	-	μm	20 (15,10)	20 (15,10)
Radial Runout ⑥	-	μm	20 (15,10)	20 (15,10)
Max Axial Load (Upright Mounting) ⑦	-	N	2310	2310
Max Axial Load (Inverted / Wall mounting)	-	N	240	240
Max Moment Load (Upright Mounting)	-	Nm	53	53
Max Moment Load (Inverted / Wall Mounting)	-	Nm	5.8	5.8
Encoder Parameters				
ABI Optical Incremental Encoder (SIN/COS)	-	lines / rev	4103	4103
ABI Optical Incremental Encoder Digital Resolution (80x)	-	counts / rev	328240	328240
ABI Optical Incremental Encoder Digital Resolution (160x)	-	counts / rev	656480	656480
ABI Optical Incremental Encoder Digital Resolution (400x)	-	counts / rev	1641200	1641200
ATOM DX Optical Incremental Encoder	-	lines / rev	8192	8192
ATOM DX Optical Incremental Encoder (200x)	-	counts / rev	1638400	1638400
Accuracy with Error Mapping ⑦	-	arc sec	+/-4	+/-4
Repeatability ⑦	-	arc sec	+/-2	+/-2
Other Information				
Insulation Class	Class B (130°C)			
Protection Grade	IP40			
Compliance with Global Standards	RoHS, CE, UL (option)			
Ambient Temperature	Operation	0°C to 40°C (non-freezing)		
	Storage	-15°C to 70°C (non-freezing)		
Ambient Humidity	Operation	10%RH to 80%RH (non-condensing)		
	Storage	10%RH to 90%RH (non-condensing)		
Recommended Ambience	Indoor (no direct sunlight); No corrosive gas, inflammable gas, oil mist or dust.			

- ① Measurement is taken at ambient temperature 25°C. Value depends on the thermal environment.
 - ② Resistance is measured by DC current with standard 0.5m cable.
 - ③ Inductance is measured by current frequency of 1kHz.
 - ④ The value is based on ABI optical SIN/COS encoder (4096x interpolation) under 330V bus voltage.
 - ⑤ Runout specification define in the datasheet is based on constant loading and temperature condition (the value in parenthesis is optional).
 - ⑥ Please refer to the illustration for different mountings.
 - ⑦ Based on ABI optical SIN/COS encoder (4096x interpolation) with standard runout.
- The contents of datasheet are subject to change without prior notice.

Dimension

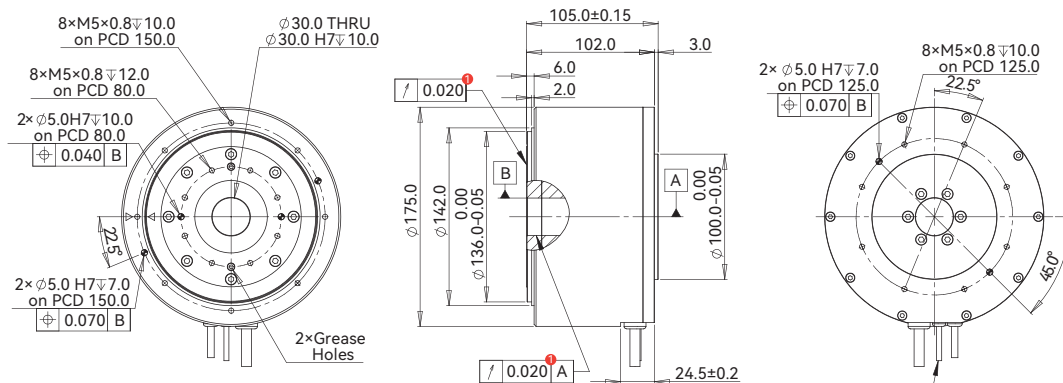

① Standard axial / radial run-out = 0.020

Torque-Speed Curve

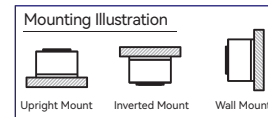
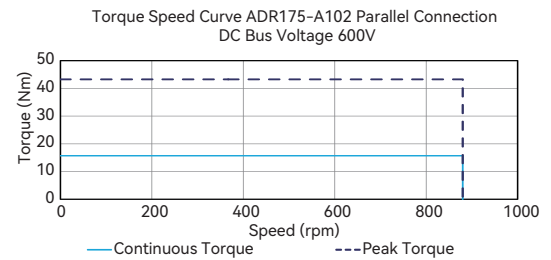
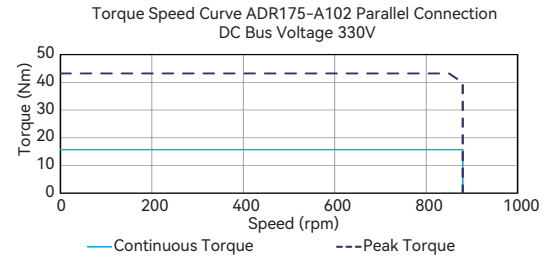
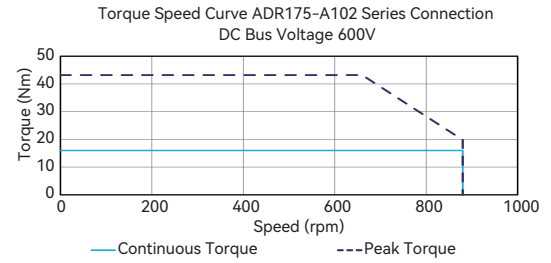
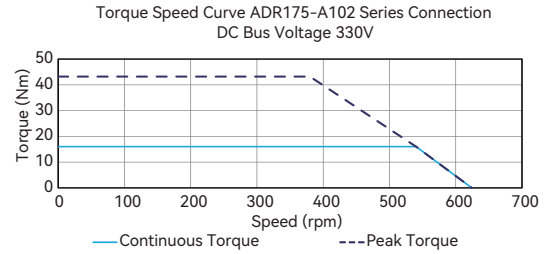

- Motor cable = φ8.0
- Hall cable = φ5.2
- Encoder cable = φ4.0

ADR175-A138

ADR175-A138					
Performance Parameters		Symbol	Unit	Series	Parallel
Continuous Torque @100°C ①		T _{cn}	Nm	30.2	30.2
Peak Torque		T _{pk}	Nm	81.4	81.4
Torque Constant ±10%		K _t	Nm/Arms	10.4	5.2
Back EMF constant ±10%		K _e	Vpeak/rpm	0.89	0.44
Motor Constant @25°C		K _m	Nm/Sqrt(W)	2.95	2.91
Resistance (L-L) @25°C ±10% ②		R ₂₅	Ω	8.30	2.13
Inductance (L-L) ±20% ③		L	mH	72.00	18.51
Electrical time constant		τ _e	ms	8.67	8.67
Continuous Current @100°C ①		I _{cn}	Arms	2.9	5.8
Peak Current		I _{pk}	Arms	8.7	17.4
Continuous Power Dissipation @100°C ①		P _{cn}	W	135.0	138.9
Max. Coil Temperature		T _{max}	°C	100.0	100.0
Thermal Dissipation Constant ①		K _{thn}	W/°C	1.8	1.9
Max. Bus Voltage		U _{bus}	Vdc	600.0	600.0
Pole Number		2P	-	16	16
Rec. Max Speed @Peak Torque ④		Ω _{max}	rpm	320	470
Rec. Max Speed @Continuous Torque ⑤		Ω _{max}	rpm	440	470
Mechanical Parameters					
Overall Mass		m _n	kg	12.7	12.7
Rotor Inertia		J _r	kg·m ²	7.621E-03	7.621E-03
Axial Runout ⑥		-	μm	20 (15,10)	20 (15,10)
Radial Runout ⑥		-	μm	20 (15,10)	20 (15,10)
Max Axial Load (Upright Mounting) ⑦		-	N	2310	2310
Max Axial Load (Inverted / Wall mounting)		-	N	240	240
Max Moment Load (Upright Mounting)		-	Nm	53	53
Max Moment Load (Inverted / Wall Mounting)		-	Nm	5.8	5.8
Encoder Parameters					
ABI Optical Incremental Encoder (SIN/COS)		-	lines / rev	4103	4103
ABI Optical Incremental Encoder Digital Resolution (80x)		-	counts / rev	328240	328240
ABI Optical Incremental Encoder Digital Resolution (160x)		-	counts / rev	656480	656480
ABI Optical Incremental Encoder Digital Resolution (400x)		-	counts / rev	1641200	1641200
ATOM DX Optical Incremental Encoder		-	lines / rev	8192	8192
ATOM DX Optical Incremental Encoder (200x)		-	counts / rev	1638400	1638400
Accuracy with Error Mapping ⑦		-	arc sec	+/-4	+/-4
Repeatability ⑦		-	arc sec	+/-2	+/-2
Other Information					
Insulation Class		Class B (130°C)			
Protection Grade		IP40			
Compliance with Global Standards		RoHS, CE, UL (option)			
Ambient Temperature		Operation	0°C to 40°C (non-freezing)		
		Storage	-15°C to 70°C (non-freezing)		
Ambient Humidity		Operation	10%RH to 80%RH (non-condensing)		
		Storage	10%RH to 90%RH (non-condensing)		
Recommended Ambience		Indoor (no direct sunlight); No corrosive gas, inflammable gas, oil mist or dust.			

- ① Measurement is taken at ambient temperature 25°C. Value depends on the thermal environment.
 - ② Resistance is measured by DC current with standard 0.5m cable.
 - ③ Inductance is measured by current frequency of 1kHz.
 - ④ The value is based on ABI optical SIN/COS encoder (4096x interpolation) under 330V bus voltage.
 - ⑤ Runout specification define in the datasheet is based on constant loading and temperature condition (the value in parenthesis is optional).
 - ⑥ Please refer to the illustration for different mountings.
 - ⑦ Based on ABI optical SIN/COS encoder (4096x interpolation) with standard runout.
- The contents of datasheet are subject to change without prior notice.

Dimension

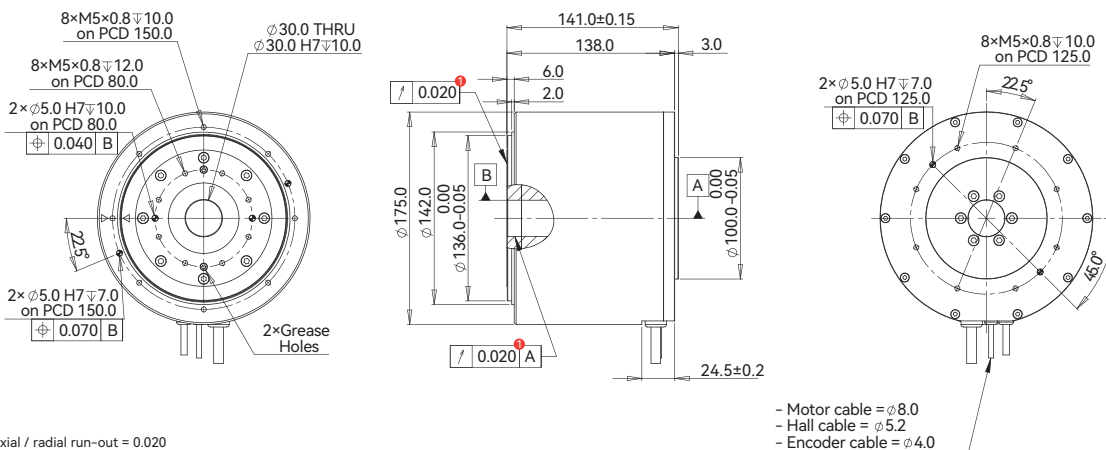

Torque-Speed Curve

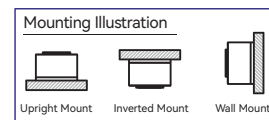
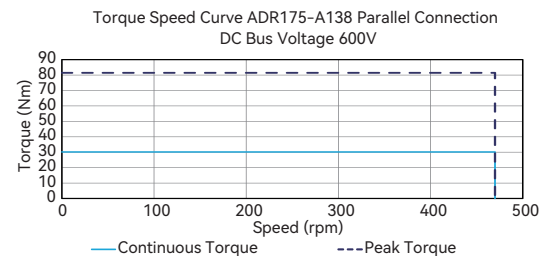
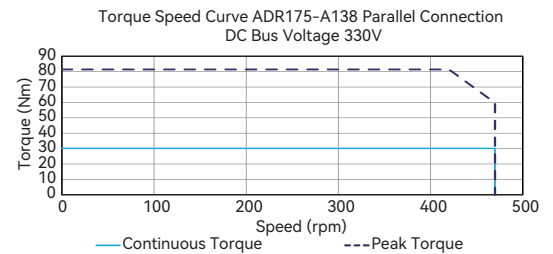
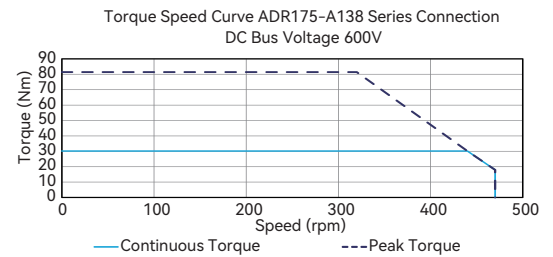
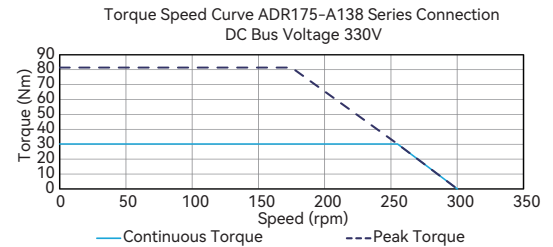

ADR220-A120

Introduction Sizing Guide Frequently Asked Questions Linear Motors Voice Coil Motors Direct Drive Rotary Motors Magnet Spring Motion Control of Gantry Stages

ADR220-A120				
Performance Parameters	Symbol	Unit	Series	Parallel
Continuous Torque @100°C ❶	T _{cn}	Nm	43.3	43.3
Peak Torque	T _{pk}	Nm	116.9	116.9
Torque Constant ±10%	K _t	Nm/Arms	11.7	3.9
Back EMF constant ±10%	K _e	Vpeak/rpm	1.00	0.33
Motor Constant @25°C	K _m	Nm/Sqrt(W)	3.94	3.70
Resistance (L-L) @25°C ±10% ❷	R ₂₅	Ω	5.87	0.74
Inductance (L-L) ±20% ❸	L	mH	53.60	6.30
Electrical time constant	τ _e	ms	9.13	8.51
Continuous Current @100°C ❶	I _{cn}	Arms	3.7	11.1
Peak Current	I _{pk}	Arms	11.1	33.3
Continuous Power Dissipation @100°C ❶	P _{zn}	W	155.4	176.3
Max. Coil Temperature	T _{max}	°C	100.0	100.0
Thermal Dissipation Constant ❶	K _{thn}	W/°C	2.1	2.4
Max. Bus Voltage	U _{bus}	Vdc	600.0	600.0
Pole Number	2P	-	24	24
Rec. Max Speed @Peak Torque ❹	Ω _{max}	rpm	265	540
Rec. Max Speed @Continuous Torque ❹	Ω _{max}	rpm	320	540
Mechanical Parameters				
Overall Mass	m _n	kg	18.3	18.3
Rotor Inertia	J _r	kg·m ²	1.786E-02	1.786E-02
Axial Runout ❺	-	μm	25 (10)	25 (10)
Radial Runout ❻	-	μm	25 (10)	25 (10)
Max Axial Load (Upright Mounting) ❷	-	N	2800	2800
Max Axial Load (Inverted / Wall mounting)	-	N	300	300
Max Moment Load (Upright Mounting)	-	Nm	72	72
Max Moment Load (Inverted / Wall Mounting)	-	Nm	7.9	7.9
Encoder Parameters				
ABI Optical Incremental Encoder (SIN/COS)	-	lines / rev	4103	4103
ABI Optical Incremental Encoder Digital Resolution (80x)	-	counts / rev	328240	328240
ABI Optical Incremental Encoder Digital Resolution (160x)	-	counts / rev	656480	656480
ABI Optical Incremental Encoder Digital Resolution (400x)	-	counts / rev	1641200	1641200
ATOM DX Optical Incremental Encoder	-	lines / rev	8192	8192
ATOM DX Optical Incremental Encoder(200x)	-	counts / rev	1638400	1638400
Accuracy with Error Mapping ❷	-	arc sec	+/-4	+/-4
Repeatability ❷	-	arc sec	+/-2	+/-2
Other Information				
Insulation Class	Class B (130°C)			
Protection Grade	IP40			
Compliance with Global Standards	RoHS, CE, UL (option)			
Ambient Temperature	Operation	0°C to 40°C (non-freezing)		
	Storage	-15°C to 70°C (non-freezing)		
Ambient Humidity	Operation	10%RH to 80%RH (non-condensing)		
	Storage	10%RH to 90%RH (non-condensing)		
Recommended Ambience	Indoor (no direct sunlight); No corrosive gas, inflammable gas, oil mist or dust.			

- ❶ Measurement is taken at ambient temperature 25°C. Value depends on the thermal environment.
 - ❷ Resistance is measured by DC current with standard 0.5m cable.
 - ❸ Inductance is measured by current frequency of 1kHz.
 - ❹ The value is based on ABI optical SIN/COS encoder (4096x interpolation) under 330V bus voltage.
 - ❺ Runout specification define in the datasheet is based on constant loading and temperature condition (the value in parenthesis is optional).
 - ❻ Please refer to the illustration for different mountings.
 - ❼ Based on ABI optical SIN/COS encoder (4096x interpolation) with standard runout.
- The contents of datasheet are subject to change without prior notice.

Dimension

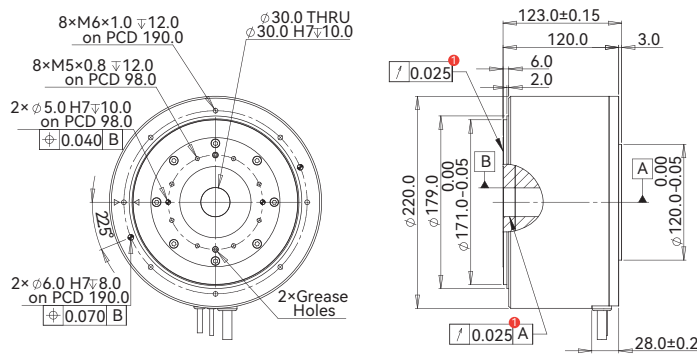

❶ Standard axial / radial run-out = 0.025

Torque-Speed Curve

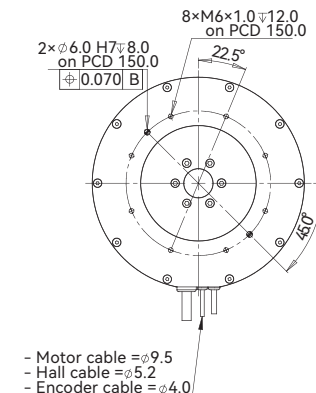
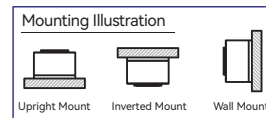
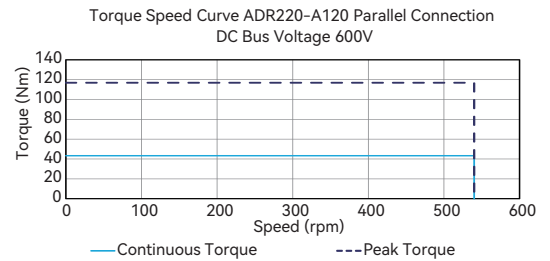
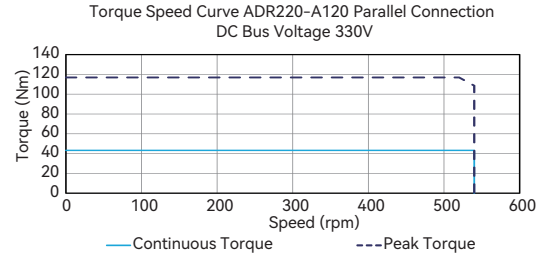
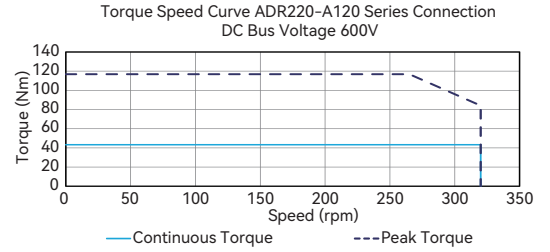
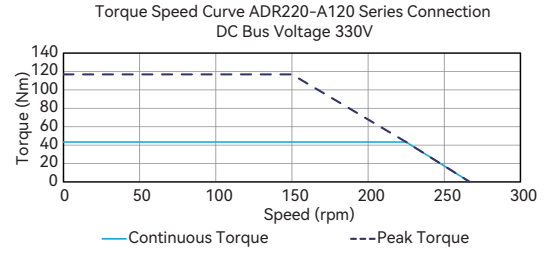

ADR220-A165

ADR220-A165				
Performance Parameters	Symbol	Unit	Series	Parallel
Continuous Torque @100°C ❶	T_{cn}	Nm	77.9	78.2
Peak Torque	T_{pk}	Nm	210.3	211.2
Torque Constant $\pm 10\%$	K_t	Nm/Arms	23.6	7.9
Back EMF constant $\pm 10\%$	K_e	Vpeak/rpm	2.02	0.68
Motor Constant @25°C	K_m	Nm/Sqrt(W)	6.00	5.89
Resistance (L-L) @25°C $\pm 10\%$ ❷	R_{25}	Ω	10.32	1.20
Inductance (L-L) $\pm 20\%$ ❸	L	mH	106.70	11.90
Electrical time constant	τ_e	ms	10.34	9.92
Continuous Current @100°C ❶	I_{cn}	Arms	3.3	9.9
Peak Current	I_{pk}	Arms	9.9	29.7
Continuous Power Dissipation @100°C ❶	P_{cn}	W	217.3	227.4
Max. Coil Temperature	T_{max}	°C	100.0	100.0
Thermal Dissipation Constant ❶	K_{thn}	W/°C	2.9	3.0
Max. Bus Voltage	U_{bus}	Vdc	600.0	600.0
Pole Number	2P	-	24	24
Rec. Max Speed @Peak Torque ❹	Ω_{max}	rpm	125	300
Rec. Max Speed @Continuous Torque ❹	Ω_{max}	rpm	190	300
Mechanical Parameters				
Overall Mass	m_n	kg	24.1	24.1
Rotor Inertia	J_r	kg·m ²	2.522E-02	2.522E-02
Axial Runout ❺	-	μm	25 (10)	25 (10)
Radial Runout ❻	-	μm	25 (10)	25 (10)
Max Axial Load (Upright Mounting) ❽	-	N	2800	2800
Max Axial Load (Inverted / Wall mounting)	-	N	300	300
Max Moment Load (Upright Mounting)	-	Nm	72	72
Max Moment Load (Inverted / Wall Mounting)	-	Nm	7.9	7.9
Encoder Parameters				
ABI Optical Incremental Encoder (SIN/COS)	-	lines / rev	4103	4103
ABI Optical Incremental Encoder Digital Resolution (80x)	-	counts / rev	328240	328240
ABI Optical Incremental Encoder Digital Resolution (160x)	-	counts / rev	656480	656480
ABI Optical Incremental Encoder Digital Resolution (400x)	-	counts / rev	1641200	1641200
ATOM DX Optical Incremental Encoder	-	lines / rev	8192	8192
ATOM DX Optical Incremental Encoder(200x)	-	counts / rev	1638400	1638400
Accuracy with Error Mapping ❹	-	arc sec	+/-4	+/-4
Repeatability ❹	-	arc sec	+/-2	+/-2
Other Information				
Insulation Class	Class B (130°C)			
Protection Grade	IP40			
Compliance with Global Standards	RoHS, CE, UL (option)			
Ambient Temperature	Operation	0°C to 40°C (non-freezing)		
	Storage	-15°C to 70°C (non-freezing)		
Ambient Humidity	Operation	10%RH to 80%RH (non-condensing)		
	Storage	10%RH to 90%RH (non-condensing)		
Recommended Ambience	Indoor (no direct sunlight); No corrosive gas, inflammable gas, oil mist or dust.			

- ❶ Measurement is taken at ambient temperature 25°C. Value depends on the thermal environment.
 - ❷ Resistance is measured by DC current with standard 0.5m cable.
 - ❸ Inductance is measured by current frequency of 1kHz.
 - ❹ The value is based on ABI optical SIN/COS encoder (4096x interpolation) under 330V bus voltage.
 - ❺ Runout specification define in the datasheet is based on constant loading and temperature condition (the value in parenthesis is optional).
 - ❻ Please refer to the illustration for different mountings.
 - ❼ Based on ABI optical SIN/COS encoder (4096x interpolation) with standard runout.
- The contents of datasheet are subject to change without prior notice.

Dimension

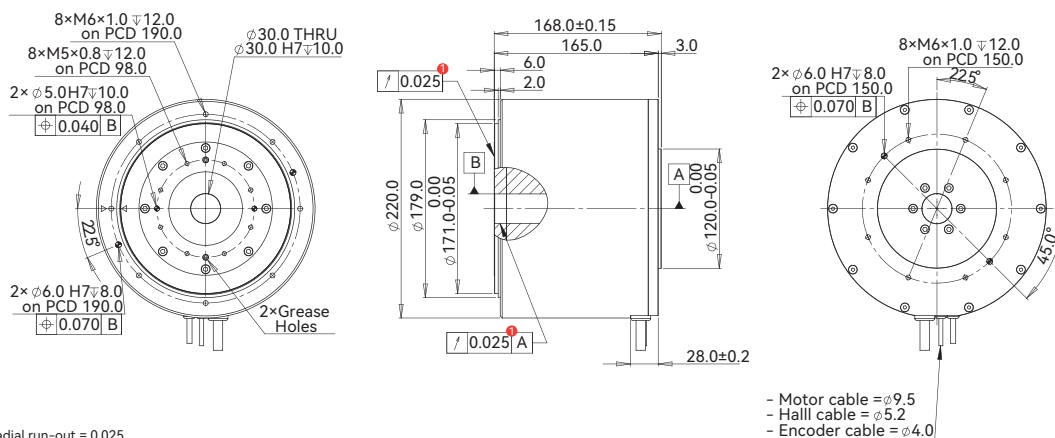

Torque-Speed Curve

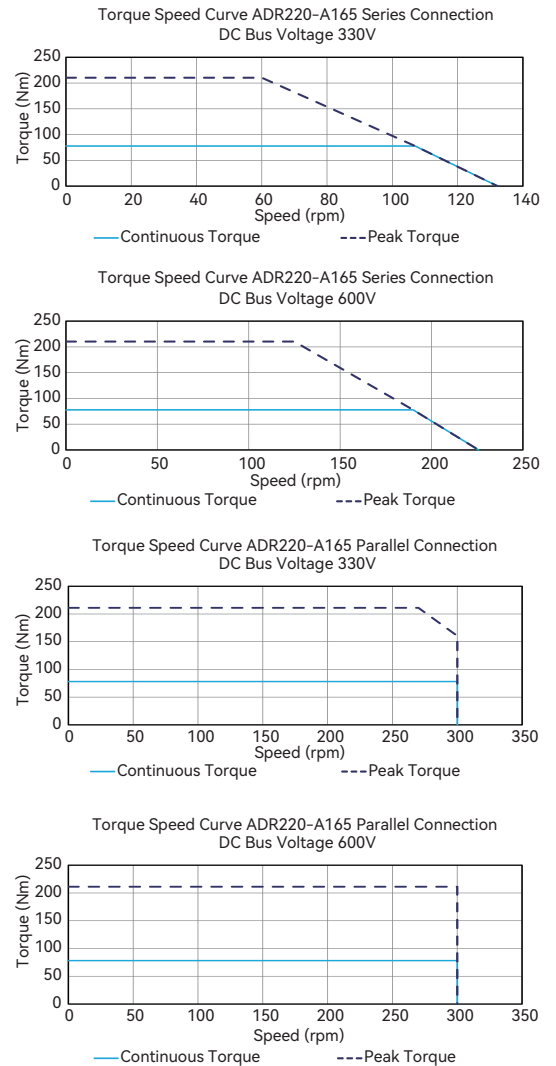

Introduction
Sizing Guide
Frequently Asked Questions
Linear Motors
Voice Coil Motors
Direct Drive Rotary Motors
Magnet Spring
Motion Control of Gantry Stages

ADR360-A150

Introduction Sizing Guide Frequently Asked Questions Linear Motors Voice Coil Motors Direct Drive Rotary Motors Magnet Spring Motion Control of Gantry Stages

ADR360-A150				
Performance Parameters	Symbol	Unit	Series	Parallel
Continuous Torque @100°C ❶	T _{cn}	Nm	184.2	184.2
Peak Torque	T _{pk}	Nm	497.2	497.2
Torque Constant ±10%	K _t	Nm/Arms	25.4	12.7
Back EMF constant ±10%	K _e	Vpeak/rpm	2.2	1.1
Motor Constant @25°C	K _m	Nm/Sqrt(W)	11.88	11.88
Resistance (L-L) @25°C ±10% ❷	R ₂₅	Ω	3.05	0.76
Inductance (L-L) ±20% ❸	L	mH	31.70	7.92
Electrical time constant	τ _e	ms	10.40	10.40
Continuous Current @100°C ❶	I _{cn}	Arms	7.3	14.5
Peak Current	I _{pk}	Arms	21.8	43.5
Continuous Power Dissipation @100°C ❶	P _{zn}	W	309.7	309.7
Max. Coil Temperature	T _{max}	°C	100.0	100.0
Thermal Dissipation Constant ❶	K _{thn}	W/°C	4.1	4.1
Max. Bus Voltage	U _{bus}	Vdc	600.0	600.0
Pole Number	2P	-	32	32
Rec. Max Speed @Peak Torque ❹	Ω _{max}	rpm	135	240
Rec. Max Speed @Continuous Torque ❹	Ω _{max}	rpm	180	240
Mechanical Parameters				
Overall Mass	m _n	kg	56.0	56.0
Rotor Inertia	J _r	kg·m ²	2.046E-01	2.046E-01
Axial Runout ❺	-	μm	40 (15)	40 (15)
Radial Runout ❺	-	μm	40 (15)	40 (15)
Max Axial Load (Upright Mounting) ❻	-	N	11200	11200
Max Axial Load (Inverted / Wall mounting)	-	N	350	350
Max Moment Load (Upright Mounting)	-	Nm	245	245
Max Moment Load (Inverted / Wall Mounting)	-	Nm	27.0	27.0
Encoder Parameters				
ABI Optical Incremental Encoder (SIN/COS)	-	lines / rev	7500	7500
ABI Optical Incremental Encoder Digital Resolution (80x)	-	counts / rev	600000	600000
ABI Optical Incremental Encoder Digital Resolution (160x)	-	counts / rev	1200000	1200000
ABI Optical Incremental Encoder Digital Resolution (400x)	-	counts / rev	3000000	3000000
ATOM DX Optical Incremental Encoder	-	lines / rev	15000	15000
ATOM DX Optical Incremental Encoder(200x)	-	counts / rev	3000000	3000000
Accuracy with Error Mapping ❷	-	arc sec	+/-4	+/-4
Repeatability ❷	-	arc sec	+/-2	+/-2
Other Information				
Insulation Class	Class B (130°C)			
Protection Grade	IP40			
Compliance with Global Standards	RoHS, CE, UL (option)			
Ambient Temperature	Operation	0°C to 40°C (non-freezing)		
	Storage	-15°C to 70°C (non-freezing)		
Ambient Humidity	Operation	10%RH to 80%RH (non-condensing)		
	Storage	10%RH to 90%RH (non-condensing)		
Recommended Ambience	Indoor (no direct sunlight); No corrosive gas, inflammable gas, oil mist or dust.			

- ❶ Measurement is taken at ambient temperature 25°C. Value depends on the thermal environment.
 - ❷ Resistance is measured by DC current with standard 0.5m cable.
 - ❸ Inductance is measured by current frequency of 1kHz.
 - ❹ The value is based on ABI optical SIN/COS encoder (4096x interpolation) under maximum bus voltage.
 - ❺ Runout specification define in the datasheet is based on constant loading and temperature condition (the value in parenthesis is optional).
 - ❻ Please refer to the illustration for different mountings.
 - ❼ Based on ABI optical SIN/COS encoder (4096x interpolation) with standard runout.
- The contents of datasheet are subject to change without prior notice.

Dimension

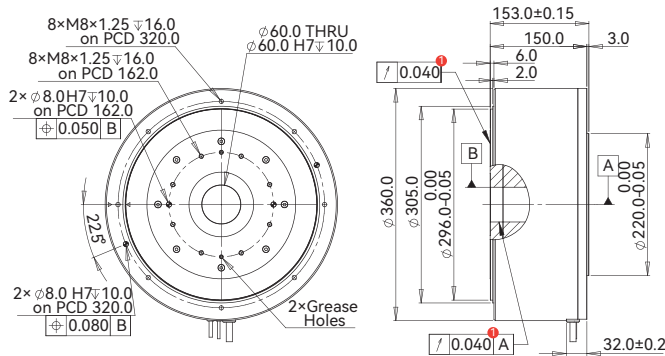

Torque-Speed Curve

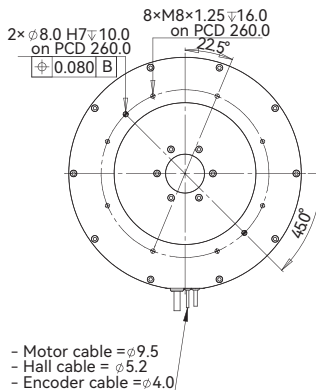
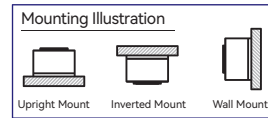
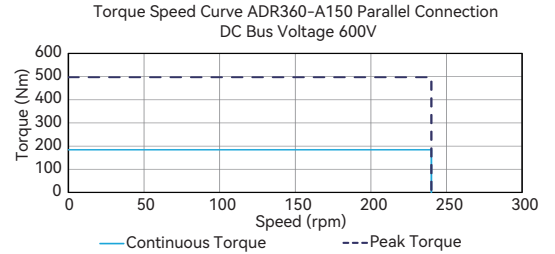
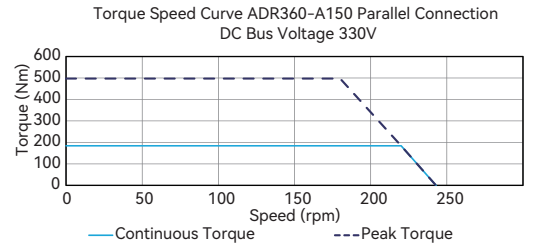
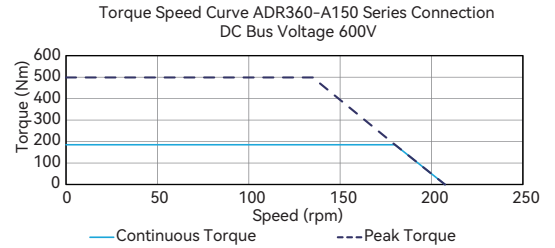
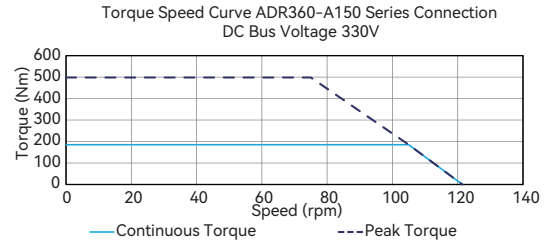

❶ Standard axial / radial run-out = 0.040

ADR360-A215

ADR360-A215					
Performance Parameters		Symbol	Unit	Series	Parallel
Continuous Torque @100°C ①		T_{cn}	Nm	407.2	407.2
Peak Torque		T_{pk}	Nm	1017.9	1017.9
Torque Constant ±10%		K_t	Nm/Arms	56.2	28.1
Back EMF constant ±10%		K_e	Vpeak/rpm	4.8	2.4
Motor Constant @25°C		K_m	Nm/Sqrt(W)	19.99	20.51
Resistance (L-L) @25°C ±10% ②		R_{25}	Ω	5.26	1.25
Inductance (L-L) ±20% ③		L	mH	54.74	13.00
Electrical time constant		τ_e	ms	10.40	10.40
Continuous Current @100°C ①		I_{cn}	Arms	7.3	14.5
Peak Current		I_{pk}	Arms	21.8	43.5
Continuous Power Dissipation @100°C ①		P_{cn}	W	535.0	508.2
Max. Coil Temperature		T_{max}	°C	100.0	100.0
Thermal Dissipation Constant ①		K_{thn}	W/°C	7.1	6.8
Max. Bus Voltage		U_{bus}	Vdc	600.0	600.0
Pole Number		2P	-	32	32
Rec. Max Speed @Peak Torque ④		Ω_{max}	rpm	70	165
Rec. Max Speed @Continuous Torque ④		Ω_{max}	rpm	95	200
Mechanical Parameters					
Overall Mass		m_n	kg	71.0	71.0
Rotor Inertia		J_r	kg·m ²	3.223E-01	3.223E-01
Axial Runout ⑤		-	μ m	40 (15)	40 (15)
Radial Runout ⑤		-	μ m	40 (15)	40 (15)
Max Axial Load (Upright Mounting) ⑥		-	N	11200	11200
Max Axial Load (Inverted / Wall mounting)		-	N	350	350
Max Moment Load (Upright Mounting)		-	Nm	245	245
Max Moment Load (Inverted / Wall Mounting)		-	Nm	27.0	27.0
Encoder Parameters					
ABI Optical Incremental Encoder (SIN/COS)		-	lines / rev	7500	7500
ABI Optical Incremental Encoder Digital Resolution (80x)		-	counts / rev	600000	600000
ABI Optical Incremental Encoder Digital Resolution (160x)		-	counts / rev	1200000	1200000
ABI Optical Incremental Encoder Digital Resolution (400x)		-	counts / rev	3000000	3000000
ATOM DX Optical Incremental Encoder		-	lines / rev	15000	15000
ATOM DX Optical Incremental Encoder(200x)		-	counts / rev	3000000	3000000
Accuracy with Error Mapping ⑦		-	arc sec	+/-4	+/-4
Repeatability ⑦		-	arc sec	+/-2	+/-2
Other Information					
Insulation Class		Class B (130°C)			
Protection Grade		IP40			
Compliance with Global Standards		RoHS, CE, UL (option)			
Ambient Temperature		Operation	0°C to 40°C (non-freezing)		
		Storage	-15°C to 70°C (non-freezing)		
Ambient Humidity		Operation	10%RH to 80%RH (non-condensing)		
		Storage	10%RH to 90%RH (non-condensing)		
Recommended Ambience		Indoor (no direct sunlight); No corrosive gas, inflammable gas, oil mist or dust.			

- ① Measurement is taken at ambient temperature 25°C. Value depends on the thermal environment.
 - ② Resistance is measured by DC current with standard 0.5m cable.
 - ③ Inductance is measured by current frequency of 1kHz.
 - ④ The value is based on ABI optical SIN/COS encoder (4096x interpolation) under maximum bus voltage.
 - ⑤ Runout specification define in the datasheet is based on constant loading and temperature condition (the value in parenthesis is optional).
 - ⑥ Please refer to the illustration for different mountings.
 - ⑦ Based on ABI optical SIN/COS encoder (4096x interpolation) with standard runout.
- The contents of datasheet are subject to change without prior notice.

Dimension

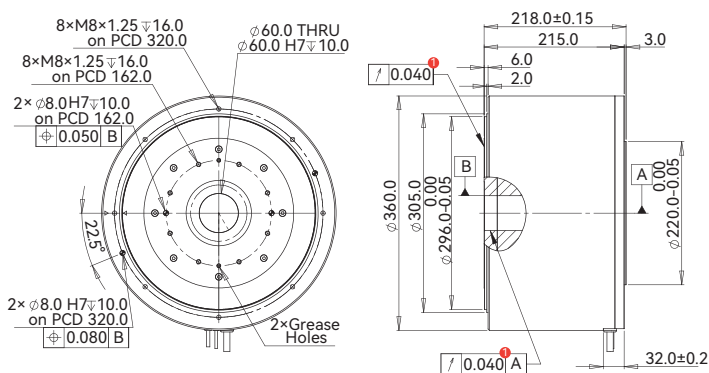

① Standard axial / radial run-out = 0.040

Torque-Speed Curve

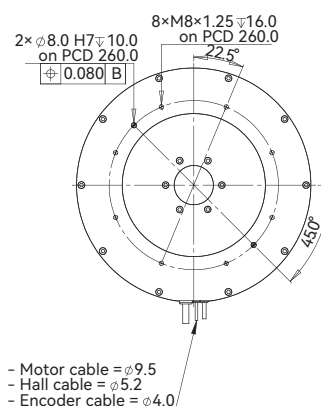
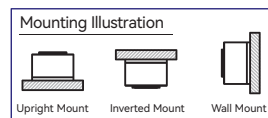
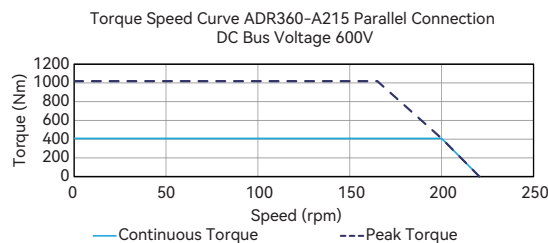
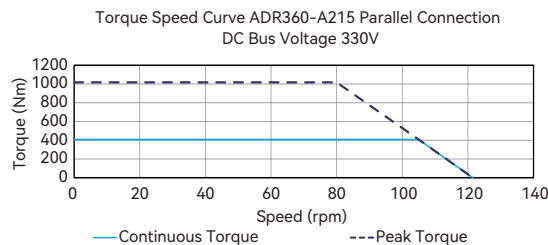
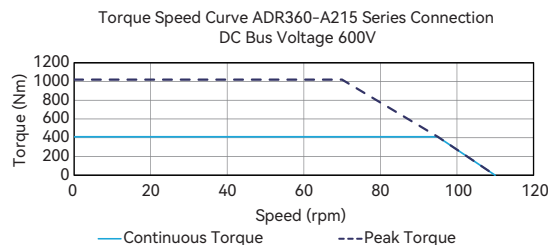
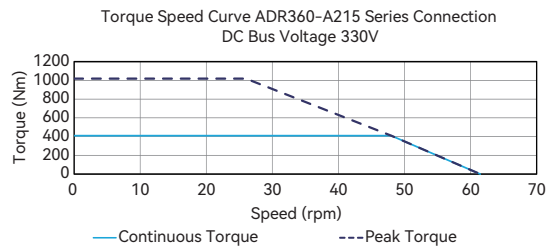

Motor Cable Connection

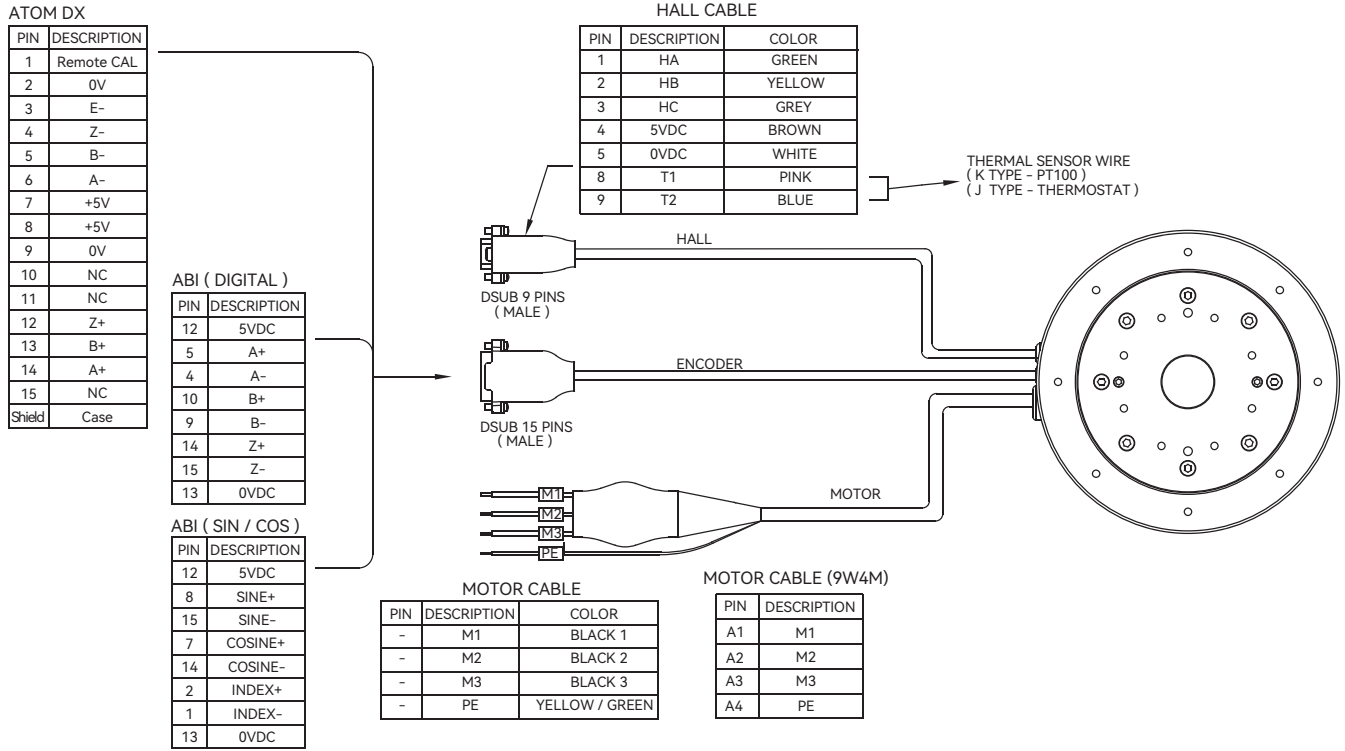

Part Numbering

ADR110-A98-S-J-H9D-0.5-FB-AB-3005-SINCOS-P15-ORB

Motor Model:
ADR110 / ADR135

Motor Height:
ADR110-A75 / A98
ADR135-A90 / A115

Winding Code:
S = Series / P = Parallel

Thermal Sensor:
J = Thermostat / K = PT100(RTD)

Sensor Cable:
H9D / NH

Design Control Code:
ORB / OUA

Runout:
P5 / P10 / P15

Interpolation:
SINCOS /
80X / 160X / 400X

Encoder:
ABI:AB-3005 / ATOM DX:R5F2

Power Cable:
FB / 9W4M

Cable Length(m):
0.5

- ① H9D = With Built-in Hall Sensor C/W 9-Pins D-Sub Connector
- ② NH = Without Built-in Hall Sensor C/W Flying Leads
- ③ FB = With Ferrite Bead C/W Flying Leads
- ④ 9W4M = Without Ferrite Bead C/W D-Sub 9W4 Male Connector
- ⑤ This item should be empty when ATOM encoder is selected
- ⑥ P5 = Axial Runout 5µm, Radial Runout is 5µm
P10 = Axial Runout 10µm, Radial Runout is 10µm
P15 = Axial Runout 15µm, Radial Runout is 15µm
- ⑦ ORB = Standard Model (for more options, please consult cust-service@akribis-sys.com)
- ⑧ OUA = UL-certified Model (for more options, please consult cust-service@akribis-sys.com)

ADR175-A138-S-J-H9D-0.5-FB-AB-4103-80X-P10-0RB

Motor Model:

ADR175 / ADR220

Motor Height:

ADR175-A102 / A138
ADR220-A120 / A165

Winding Code:

S = Series / P = Parallel

Thermal Sensor:

J = Thermostat / K = PT100(RTD)

Sensor Cable:

H9D / NH

- ① H9D = With Built-in Hall Sensor C/W 9-Pins D-Sub Connector
- ② NH = Without Built-in Hall Sensor C/W Flying Leads
- ③ FB = With Ferrite Bead C/W Flying Leads
- ④ 9W4M = Without Ferrite Bead C/W D-Sub 9W4 Male Connector
- ⑤ This item should be empty when ATOM encoder is selected
- ⑥ ADR175 / ADR220 : P10 = Axial Runout 10µm, Radial Runout is 10µm
ADR175 : P15=Axial Runout 15µm, Radial Runout is 15µm
ADR175 : P20 = Axial Runout 20µm, Radial Runout is 20µm
ADR220 : P25 = Axial Runout 25µm, Radial Runout is 25µm

- ⑦ 0RB = Standard Model (for more options, please consult cust-service@akribis-sys.com)
- ⑧ 0UA = UL-certified Model (for more options, please consult cust-service@akribis-sys.com)

Design Control Code:

0RB / 0UA

Runout:

P10 / P15 / P20 / P25

Interpolation:

SINCOS / 80X
160X / 200X / 400X

Encoder:

ABI:AB-4103 / ATOM DX:R5G2

Power Cable:

FB / 9W4M

Cable Length (m):

0.5

ADR360-A150-S-J-H9D-0.5-FB-AB-7500-400X-P15-0RB

Motor Model:

ADR360

Motor Height:

A150 / A215

Winding Code:

S = Series / P = Parallel

Thermal Sensor:

J = Thermostat / K = PT100(RTD)

Sensor Cable:

H9D / NH

- ① H9D = With Built-in Hall Sensor C/W 9-Pins D-Sub Connector
- ② NH = Without Built-in Hall Sensor C/W Flying Leads
- ③ FB = With Ferrite Bead C/W Flying Leads
- ④ 9W4M = Without Ferrite Bead C/W D-Sub 9W4 Male Connector
- ⑤ This item should be empty when ATOM encoder is selected
- ⑥ P15=Axial Runout 15µm, Radial Runout is 15µm
P40=Axial Runout 40µm, Radial Runout is 40µm

- ⑦ 0RB = Standard Model (for more options, please consult cust-service@akribis-sys.com)
- ⑧ 0UA = UL-certified Model (for more options, please consult cust-service@akribis-sys.com)

Design Control Code:

0RB / 0UA

Runout:

P15 / P40

Interpolation:

SINCOS / 80X
160X / 200X / 400X

Encoder:

ABI:AB-7500 / ATOM DX:R5G2

Power Cable:

FB / 9W4M

Cable Length (m):

0.5