

AMS SERIES LINEAR MODULE

- ▶ Low profile
- ▶ Direct drive technology
- ▶ High response
- ▶ High precision optical encoder
- ▶ Stackable configuration

EN-26.3.1

Introduction

The AMS series micro positioning stage consists of micro linear motor, micro guide rail, encoder position feedback and a structural base. The internal structure is extremely compact. It is a high-precision positioning motion stage.

The encoder position feedback built in AMS series micro positioning stage can be selected according to the actual technical requirements. Customization service is available.

Continuous Force $F_{cn} = 4.6\text{N}$

Peak Force $F_{pk} = 8.4\text{N}$



Features

- ▶ Direct-drive, compact design
- ▶ Stroke from 15mm and other lengths of travel can be customized
- ▶ Built-in grating scale and repeatability up to $\pm 0.3\mu\text{m}$
- ▶ Optional resolution of $0.2\mu\text{m}$, $0.05\mu\text{m}$, SINCOS
- ▶ It can be combined flexibly to form an XY stage or with AMR to form an XT or XYT stage

Applications

Submicron positioning, optical alignment stage, force control.

They are applied to point-to-point high-speed positioning, optical alignment, Z-axis optical focusing, high speed pick and place, flying probe test and fiber optical alignment for automation equipment of all industries.

Miniature Modules	■ Continuous Force (F_{cn}) ■ Peak Force (F_{pk})						Unit: N	Stroke (mm)	Repeatability (μm)	Page
	1	2	4	6	8	10				
 AMS65								15	up to ± 0.3	131

Note:

ⓘ Longer stroke available upon request.

★ Products can be customized to meet specific working environments, please contact cust-service@akribis-sys.com.

AMS65

Motor Specifications	Unit	Value	
Motor	-	AMS65X	
Continuous Force (NC) @100°C ^{1 2}	N	4.6	
Peak Force ³	N	8.4	
Force Constant ±10% ⁴	N/A	1.6	
Back EMF Constant ±10% ⁴	V/(m/s)	1.6	
Resistance @25°C ±10% ⁵	Ω	1.3	
Inductance ±20% ⁵	mH	0.65	
Continuous Current (NC) @100°C ¹	A	2.9	
Peak Current	A	5.2	
Max. Voltage	Vdc	48	
Mechanical Specifications	Unit	Value	
Precision Grade	-	P	N
Effective Stroke	mm	15	
Resolution	μm	SINCOS/0.05	0.2
Repeatability	μm	±0.3	±1.0
Horizontal Straightness	μm	±1.5	
Vertical Straightness	μm	±1.5	
Rated Payload ^{6 6}	kg	1.40	
No-Load Moving Mass	kg	0.18	
No-Load Total Mass	kg	0.42	
Max. Static Moment ⁶	Nm	0.31	

- ¹ Measurement is taken at ambient temperature 25°C. Value depends on the thermal environment.
- ² The values are at mid stroke.
- ³ Resistance is measured by DC current with standard 0.5m cable.
- ⁴ Inductance is measured by current frequency of 1kHz.
- ⁵ Load capacity of module without cantilever.
- ⁶ This value is based on providing a higher control bandwidth, please contact cust-service@akribis-sys.com for higher load requirements. The contents of datasheet are subject to change without prior notice.

Dimensional Drawing

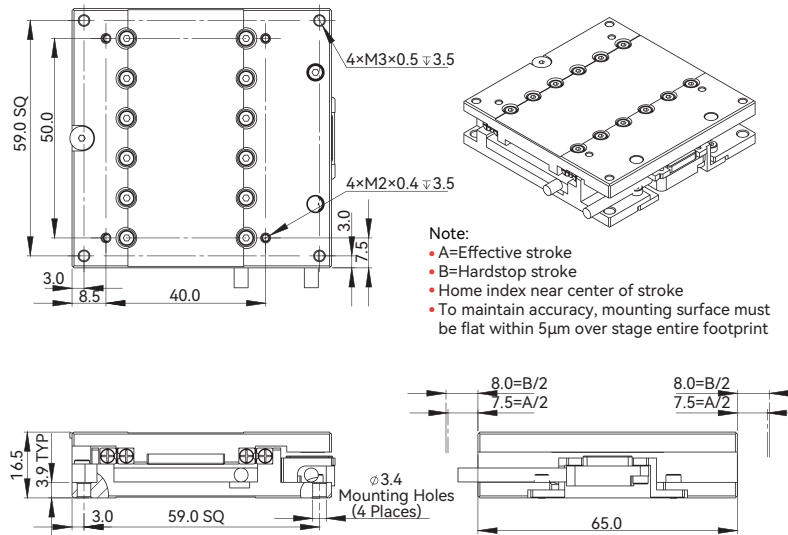

Ordering Part Number (OPN)

AMS65-E15-A0G4-A1

Model:

AMS65

Precision Grade:

Unmarked: Normal ¹

Cover Type:

E: EN

Effective Stroke:

15: 15mm

Termination:

- 1: Motor: Flying Leads/Encoder: DSUB 15
- 2: Motor: TYCO2/Encoder: DSUB 15

Cable Length:

- A: 0.5m
- B: 3.0m

Scale Type:

- 4: Nickel, 14ppm/K

Encoder Type:

- A0G: ABI-21_TTL (0.2μm)

AMS65P-E15-R0A2-A1

Model:

AMS65

Precision Grade:

P: Precision ²

Cover Type:

E: EN

Effective Stroke:

15: 15mm

Termination:

- 1: Motor: Flying Leads/Encoder: DSUB 15
- 2: Motor: TYCO2/Encoder: DSUB 15

Cable Length:

- A: 0.5m
- B: 3.0m

Scale Type:

- 2: Glass G8 Soda Lime, 8ppm/K

Encoder Type:

- R0A: ATOM2, SINCOS (1Vpp)
- R0J: ATOM2, TTL (0.05μm)

Note:

- ¹ Normal Grade uses non anti-creep roller.
- ² Precision Grade uses anti-creep roller.
- ★ Default mounting orientation for this module is horizontal. For other mounting orientations, please contact cust-service@akribis-sys.com.

AML

Motor Performance Parameters	Unit	AML40-10	AML65-15	AML80-20
Continuous Force @100°C ^{1 2}	N	2.3	5.9	9.6
Peak Force ²	N	6.9	17.7	28.8
Force Constant ±10% ²	N/A	0.8	2.2	4.5
Back EMF Constant ±10% ²	V/(m/s)	0.8	2.2	4.5
Motor Constant @25°C ²	N/Sqrt(W)	0.84	1.66	2.50
Resistance @25°C ±10% ³	Ω	0.89	1.76	3.26
Inductance ±20% ⁴	mH	0.15	0.72	2.53
Electrical Time Constant	ms	0.16	0.41	0.78
Continuous Current @100°C ¹	A	2.9	2.7	2.1
Peak Current	A	8.7	8.0	6.4
Continuous Power Dissipation @100°C ¹	W	9.6	16.3	19.1
Max. Coil Temperature	°C	100	100	100
Thermal Dissipation Constant ¹	W/°C	0.13	0.22	0.25
Max. Voltage	Vdc	48	48	48

Note:

- ¹ Measurement is taken at ambient temperature 25°C. Value depends on the thermal environment.
- ² The values are at mid stroke.
- ³ Resistance is measured by DC current with standard 0.5m cable.
- ⁴ Inductance is measured by current frequency of 1kHz.

AMZ

Motor Performance Parameters	Unit	AVM30-15
Continuous Force @100°C ^{1 2}	N	4.43
Peak Force ²	N	28.2
Force Constant ±10% ²	N/A	7.03
Back EMF Constant ±10% ²	V/(m/s)	7.03
Motor Constant @25°C ²	N/Sqrt(W)	2.20
Resistance @25°C ±10% ³	Ω	10.24
Inductance ±20% ⁴	mH	2.82
Electrical Time Constant	ms	0.28
Continuous Current @100°C ¹	A	0.6
Peak Current	A	4.0
Continuous Power Dissipation @100°C ¹	W	5.2
Max. Coil Temperature	°C	100
Thermal Dissipation Constant ¹	W/°C	0.07
Max. Voltage	Vdc	60

Note:

- ¹ Measurement is taken at ambient temperature 25°C. Value depends on the thermal environment.
- ² The values are at mid stroke.
- ³ Resistance is measured by DC current with standard 0.5m cable.
- ⁴ Inductance is measured by current frequency of 1kHz.

AMS

Motor Performance Parameters	Unit	AMS65X
Continuous Force @100°C ^{1 2}	N	4.6
Peak Force ²	N	8.4
Force Constant ±10% ²	N/A	1.6
Back EMF Constant ±10% ²	V/(m/s)	1.6
Motor Constant @25°C ²	N/Sqrt(W)	1.4
Resistance @25°C ±10% ³	Ω	1.3
Inductance ±20% ⁴	mH	0.65
Electrical Time Constant	ms	0.5
Continuous Current @100°C ¹	A	2.9
Peak Current	A	5.2
Continuous Power Dissipation @100°C ¹	W	13.5
Max. Coil Temperature	°C	100
Thermal Dissipation Constant ¹	W/°C	0.18
Max. Voltage	Vdc	48

Note:

- ¹ Measurement is taken at ambient temperature 25°C. Value depends on the thermal environment.
- ² The values are at mid stroke.
- ³ Resistance is measured by DC current with standard 0.5m cable.
- ⁴ Inductance is measured by current frequency of 1kHz.