



ALM-T SERIES

- ▶ Small thickness, light weight and high force density
- ▶ Zero cogging force and smooth operation
- ▶ High dynamic response
- ▶ Optional digital hall modules

EN-26.3.1

Introduction

ALM-T is a kind of ironless linear motor, featuring zero cogging force, light weight and high force density. It's suitable for applications with demanding velocity ripple and dynamic response, as well as force control application.

Continuous force $F_{cn} = 10.0N \sim 850.5N$

Peak force $F_{pk} = 36.0N \sim 4233.6N$



Features

- ▶ Small thickness, light weight and high force density
- ▶ Zero cogging force and smooth operation
- ▶ High dynamic response
- ▶ Optional digital hall modules

Applications

The ALM-T motors are suitable to be integrated in modules with small thickness, running with high speed, especially in areas such as:

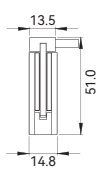
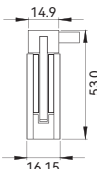
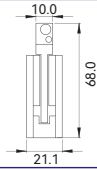
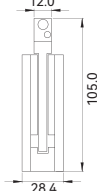
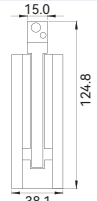
- ▶ Semiconductor
- ▶ Flat panel display
- ▶ Ultra-precision stages
- ▶ Biomedicine / Lab automation
- ▶ Optics

	Series	Coil Length (mm)	● Continuous Force (F_{cn}) / ■ PeakForce (F_{pk})						Unit: N
			10	50	200	400	600	800
	ALM015-T-B1	34.0	●10.0 / ■36.0						
	ALM015-T-B2	67.0	●20.0 / ■72.0						
	ALM016-T-B1	49.0	●19.5 / ■42.5						
	ALM016-T-B2	97.0	●39.0 / ■85.0						
	ALM021-T-B1	78.0	●28.6 / ■99.5						
	ALM021-T-B2	138.0	●57.1 / ■199.1						
	ALM021-T-B3	198.0	●85.7 / ■298.6						
	ALM021-T-B4	258.0	●114.2 / ■398.2						
	ALM028-T-B1	106.0	●74.4 / ■256.9						
	ALM028-T-B2	190.0	●148.7 / ■513.8						
	ALM028-T-B3	274.0	●223.1 / ■770.6						
	ALM028-T-B4	358.0	●297.4 / ■1027.5						
	ALM028-T-B5	442.0	●371.8 / ■1284.4						
	ALM038-T-B1	134.0	●125.1 / ■622.7						
	ALM038-T-B2	248.0	●250.2 / ■1245.4						
	ALM038-T-B3	362.0	●375.3 / ■1868.2						
	ALM038-T-B4	476.0	●500.4 / ■2490.9						
	ALM038-T-B6	704.0	●750.6 / ■3736.3						
	ALM048-T-B1	134.0	●141.8 / ■705.6						
	ALM048-T-B2	248.0	●283.5 / ■1411.2						
	ALM048-T-B3	362.0	●425.3 / ■2116.8						
	ALM048-T-B4	476.0	●567.0 / ■2822.4						
	ALM048-T-B6	704.0	●850.5 / ■4233.6						

ALM015-T

			ALM015-T-B1	ALM015-T-B2
Performance Parameters	Symbol	Unit	M	M
Continuous Force (NC) @100°C ①②	F _{cn}	N	10.0	20.0
Stall Force (NC) @100°C ③④	F _{sn}	N	8.3	16.7
Peak Force	F _{pk}	N	36.0	72.0
Force Constant ±10%	K _f	N/Arms	8.1	10.9
Back EMF Constant ±10%	K _e	Vpeak/(m/s)	6.6	8.9
Motor Constant @25°C	K _m	N/Sqrt(W)	3.1	4.3
Resistance (L-L) @25°C ±10% ⑤	R ₂₅	Ω	4.51	4.30
Inductance (L-L) ±30% ⑥	L	mH	0.58	0.60
Electrical Time Constant	T _e	ms	0.13	0.14
Continuous current (NC) @100°C ①②	I _{cn}	Arms	1.23	1.83
Stall current (NC) @100°C ③④	I _{sn}	Arms	1.03	1.53
Peak current	I _{pk}	Arms	4.4	6.6
Continuous Power Dissipation (NC) @100°C ①②	P _{cn}	W	13.3	28.0
Max. Coil Temperature	T _{max}	°C	100.0	100.0
Thermal Dissipation Constant (NC) ④⑤	K _{thn}	W/°C	0.18	0.37
Max bus Voltage	U _{bus}	Vdc	60	60
Magnetic Period	T _N	mm	16.5	16.5
Attraction Force	F _a	N	0.0	0.0
Mechanical Parameters				
Coil Mass (NC) ⑥	m _{cn}	kg	0.028	0.052
Coil Length (NC)	L _{cn}	mm	34.0	67.0
Track Mass Per Meter	m _{track}	kg/m	3.2	3.2
Other Information				
Insulation Class	Class B (130°C)			
Protection Grade	IP00			
Compliance with Global Standards	RoHS,CE			
Ambient Temperature	Operation	0°C to 40°C (non-freezing)		
	Storage	-15°C to 70°C (non-freezing)		
Ambient Humidity	Operation	10%RH to 80%RH (non-condensing)		
	Storage	10%RH to 90%RH (non-condensing)		
Recommended Ambience	Indoor (no direct sunlight); No corrosive gas, inflammable gas, oil mist or dust			

- ① Measurement is taken at ambient temperature 25°C. Abbreviations: NC-Natural Cooling
 - ② Value depends on the thermal environment. Please consult the technical department for details
 - ③ Minimum heatsink area is 0.03m² and minimum speed is 10mm/s
 - ④ Resistance is measured by DC current with standard 0.5m cable
 - ⑤ Inductance is measured by current frequency of 1kHz
 - ⑥ Coil mass does not include hall module mass
- The contents of datasheet are subject to change without prior notice

Dimensional Drawing

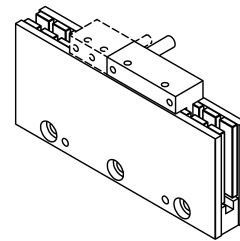
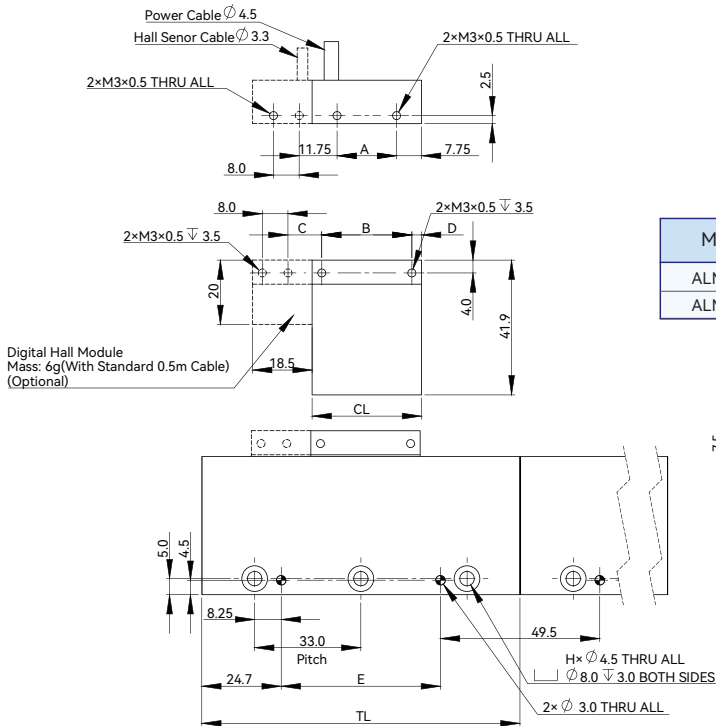

Motor Coil	Coil Length "CL"	Hole Pitch "A"	Hole Pitch "B"	Hole Pitch "C"	"D"
ALM015-T-B1	34.0	18.5	28.0	10.5	3.0
ALM015-T-B2	67.0	51.5	59.0	11.5	4.0

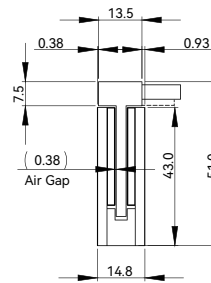

Motor Track	Track Length "TL"	Pin Hole Pitch "E"	No. of Hole "H"
ALM015-T-TL066	65.9	16.5	2
ALM015-T-TL099	98.9	49.5	3
ALM015-T-TL264	263.9	214.5	8

Force-Speed Curve

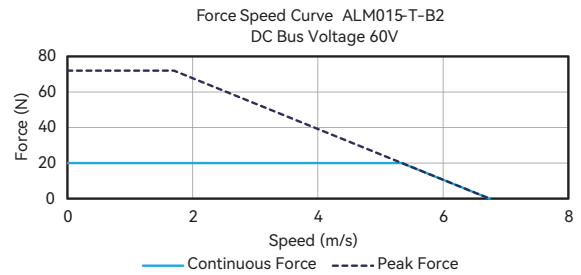
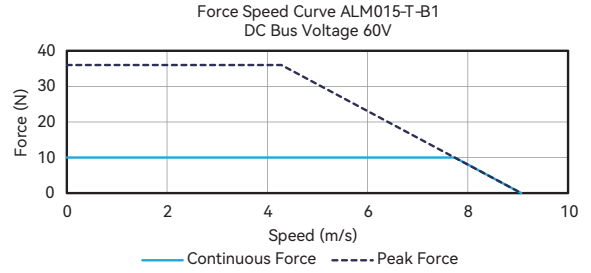

Part Numbering

Motor Coil

ALM015-T-B1-N-XX-M-NF-005-XF-000

Model:

ALM015-T

Size:

B1 / B2

Cooling Type:

N¹

Thermal Sensor:

XX²

- ¹ N = Natural Cooling
- ² XX = No Temperature Sensor
- ³ NF = Without Built-in Hall Sensor C/W Flying Leads
- ⁴ HF = With Built-in Hall Sensor & Hall Cable C/W Flying Leads
- ⁵ HL = With Hall Sensor & Hall Cable C/W MATE-N-LOK Plug
- ⁶ 005 = 0.5m; 030 = 3.0m
- ⁷ XF = Without Ferrite Bead C/W Flying Leads
- ⁸ XL = Without Ferrite Bead C/W MATE-N-LOK Plug

Design Control Code:

000

Power Cable:

XF⁷ / XL⁸

Cable Length:

005 / 030⁶

Hall Sensor Cable:

NF³ / HF⁴ / HL⁵

Winding Code:

M

Motor Track

ALM015-T-TL066-TN-000

Model:

ALM015-T

Track Length:

TL066 / TL099 / TL264

- ¹ TN = Standard Track, No Cover

Design Control Code:

000

Track Type:

TN¹

Part Numbering

Motor Coil

ALM016-T-B1-N-KX-M-NF-005-XF-000

Model:

ALM016-T

Size:

B1 / B2

Cooling Type:

N

Thermal Sensor:

KX

- ① N = Natural cooling
- ② KX = PT100 (RTD)
- ③ NF = Without Built-in Hall Sensor C/W Flying Leads
- ④ HF = With Built-in Hall Sensor & Hall Cable C/W Flying Leads
- ⑤ HL = With Hall Sensor & Hall Cable C/W MATE-N-LOK Plug
- ⑥ 005 = 0.5m; 030 = 3.0m
- ⑦ XF = Without Ferrite Bead C/W Flying Leads
- ⑧ XL = Without Ferrite Bead C/W MATE-N-LOK Plug

Design Control Code:

000

Power Cable:

XF / XL

Cable Length:

005 / 030

Hall Sensor Cable:

NF / HF / HL

Winding Code:

M

Motor Track

ALM016-T-TL072-TN-000

Model:

ALM016-T

Track Length:

TL072 / TL120

- ① TN = Standard Track, No Cover

Design Control Code:

000

Track Type:

TN

ALM021-T

Performance Parameters	Symbol	Unit	ALM021-T-B1		ALM021-T-B2		ALM021-T-B3		ALM021-T-B4	
			M	H	M	H	M	H	M	H
Continuous Force (NC) @110°C ①	F _{cn}	N	28.6	28.6	57.1	57.1	85.7	85.7	114.2	114.2
Peak Force	F _{pk}	N	99.5	99.5	199.1	199.1	298.6	298.6	398.2	398.2
Force Constant ±10%	K _f	N/Arms	42.0	21.0	42.0	21.0	42.0	21.0	42.0	21.0
Back EMF Constant ±10%	K _e	Vpeak/(m/s)	34.3	17.1	34.3	17.1	34.3	17.1	34.3	17.1
Motor Constant @25°C	K _m	N/Sqrt(W)	5.2	5.2	7.3	7.3	8.9	9.0	10.3	10.3
Resistance (L-L) @25°C ±10% ②	R ₂₅	Ω	44.20	11.00	22.10	5.50	14.73	3.67	11.05	2.75
Inductance (L-L) ±30% ③	L	mH	15.30	3.80	7.65	1.90	5.10	1.27	3.83	0.95
Electrical Time Constant	τ _e	ms	0.35	0.35	0.35	0.35	0.35	0.35	0.35	0.35
Continuous Current (NC) @110°C ①	I _{cn}	Arms	0.7	1.4	1.4	2.8	2.1	4.1	2.8	5.5
Peak Current	I _{pk}	Arms	2.4	4.8	4.8	9.6	7.2	14.4	9.6	19.2
Continuous Power Dissipation (NC) @110°C ①	P _{cn}	W	42.0	42.0	83.9	83.9	125.9	125.9	167.8	167.8
Max. Coil Temperature	T _{max}	°C	110.0	110.0	110.0	110.0	110.0	110.0	110.0	110.0
Thermal Dissipation Constant (NC) ①	K _{thn}	W/°C	0.5	0.5	1.0	1.0	1.5	1.5	2.0	2.0
Temperature Sensor	-	-	PTC/NTC	PTC/NTC	PTC/NTC	PTC/NTC	PTC/NTC	PTC/NTC	PTC/NTC	PTC/NTC
Max. Bus Voltage	U _{bus}	Vdc	330.0	330.0	330.0	330.0	330.0	330.0	330.0	330.0
Magnetic Period	τ _{NN}	mm	30.0	30.0	30.0	30.0	30.0	30.0	30.0	30.0
Attraction Force	F _a	N	0	0	0	0	0	0	0	0
Mechanical Parameters										
Coil Mass (NC) ④	m _{cn}	kg	0.08	0.08	0.17	0.17	0.23	0.23	0.30	0.30
Coil Length (NC)	L _{cn}	mm	78.0	78.0	138.0	138.0	198.0	198.0	258.0	258.0
Track Mass Per Meter	m _{track}	kg/m	4.7	4.7	4.7	4.7	4.7	4.7	4.7	4.7
Other Information										
Insulation Class	Class B (130°C)									
Protection Grade	IP00									
Compliance with Global Standards	RoHS, CE									
Ambient Temperature	Operation	0°C to 40°C (non-freezing)								
	Storage	-15°C to 70°C (non-freezing)								
Ambient Humidity	Operation	10%RH to 80%RH (non-condensing)								
	Storage	10%RH to 90%RH (non-condensing)								
Recommended Ambience	Indoor (no direct sunlight); No corrosive gas, inflammable gas, oil mist or dust.									

① Measurement is taken at ambient temperature 25°C. Value depends on the thermal environment. Abbreviations: NC-Natural Cooling.

② Resistance is measured by DC current with standard 0.5 m cable.

③ Inductance is measured by current frequency of 1 kHz.

④ Coil mass does not include hall module mass.

The contents of datasheet are subject to change without prior notice.

Dimensional Drawing

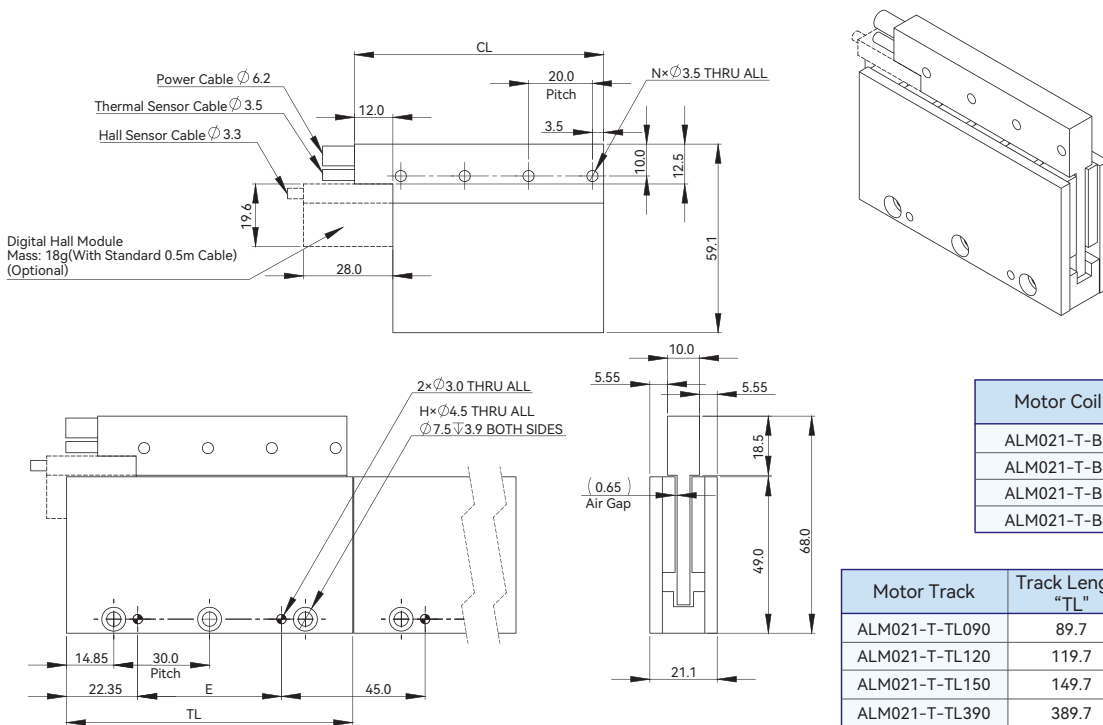

Motor Coil	Coil Length "CL"	No. of Holes "N"
ALM021-T-B1	78.0	4
ALM021-T-B2	138.0	7
ALM021-T-B3	198.0	10
ALM021-T-B4	258.0	13

Motor Track	Track Length "TL"	Pin Hole Pitch "E"	No. of Holes "H"
ALM021-T-TL090	89.7	60.0	3
ALM021-T-TL120	119.7	90.0	4
ALM021-T-TL150	149.7	120.0	5
ALM021-T-TL390	389.7	360.0	13

Force-Speed Curve

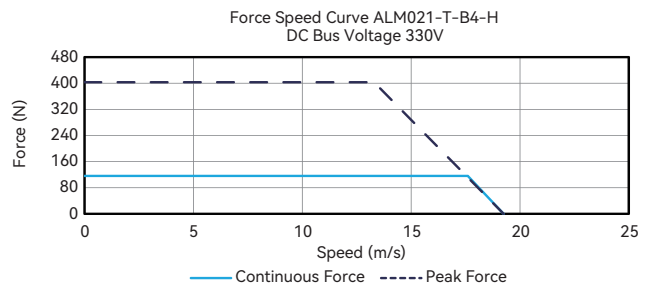
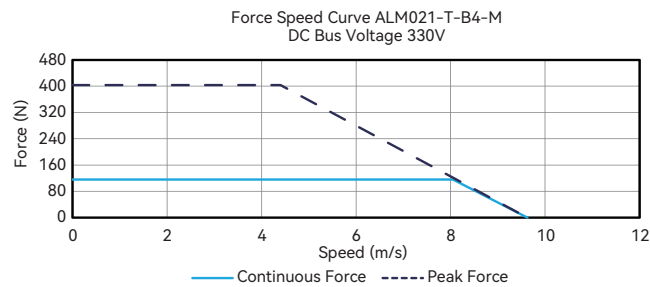
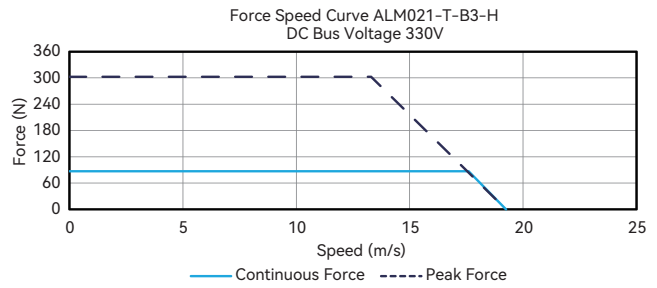
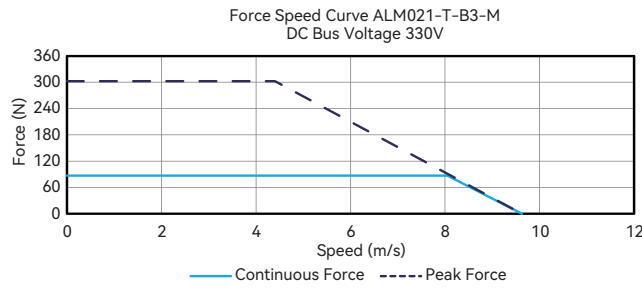
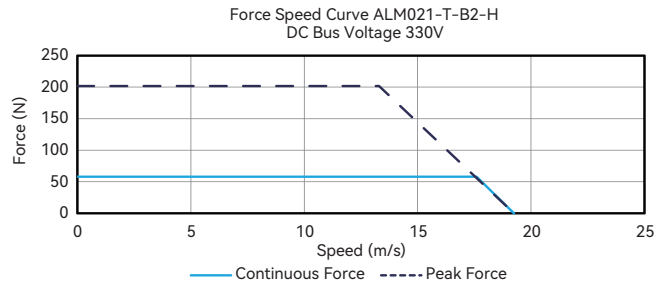
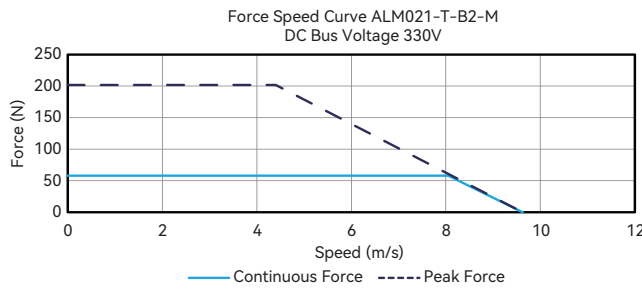
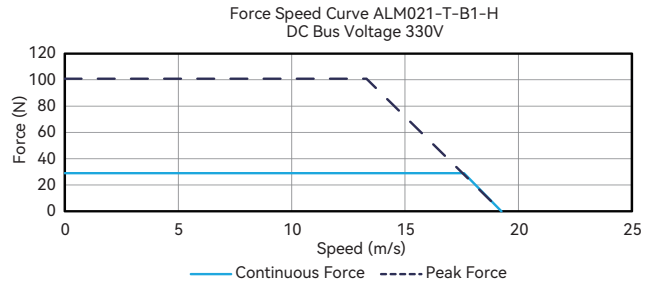
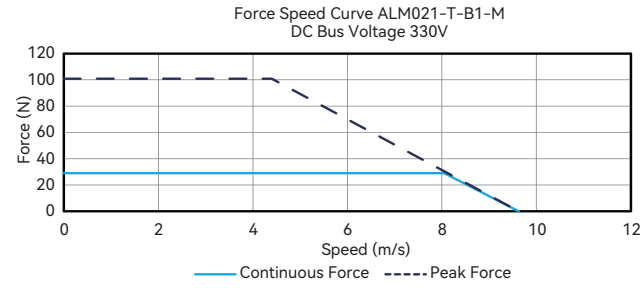

Part Numbering

Introduction | Sizing Guide | Frequently Asked Questions | Linear Motors | Voice Coil Motors | Direct Drive Rotary Motors | Magnet Spring Motion Control of Gantry Stages | Akribis systems

Motor Coil

ALM021-T-B1-N-NP-M-NF-005-XF-000

Model:

ALM021-T

Size:

B1 / B2 / B3 / B4

Cooling Type:

N

Thermal Sensor:

NP

1 N = Natural Cooling

2 NP = NTC+PTC

3 M = Mid speed winding

4 H = High speed winding

5 NF = Without Built-in Hall Sensor C/W Flying Leads

6 HF = With Built-in Hall Sensor & Hall Cable C/W Flying Leads

7 005 = 0.5m; 030 = 3.0m

8 XF = Without Ferrite Bead C/W Flying Leads

(Cables with connectors can be customized, for more options, please consult cust-service@akribis-sys.com)

Design Control Code:

000

Power Cable:

XF

Cable Length:

005 / 030

Hall Sensor Cable:

NF / HF

Winding Code:

M / H

Motor Track

ALM021-T-TL120-TN-000

Model:

ALM021-T

Track Length:

TL090 / TL120 / TL150 / TL390

1 TN = Standard Track, No Cover

Design Control Code:

000

Track Type:

TN

ALM028-T

Performance Parameters	Symbol	Unit	ALM028-T-B1		ALM028-T-B2		ALM028-T-B3		ALM028-T-B4		ALM028-T-B5	
			M	H	M	H	M	H	M	H	M	H
Continuous Force (NC) @110°C ①	F _{cn}	N	74.4	74.4	148.7	148.7	223.1	223.1	297.4	297.4	371.8	371.8
Peak Force	F _{pk}	N	256.9	256.9	513.8	513.8	770.6	770.6	1027.5	1027.5	1284.4	1284.4
Force Constant ±10%	K _f	N/Arms	67.6	27.6	67.6	27.6	67.6	27.6	67.6	27.6	67.6	27.6
Back EMF Constant ±10%	K _e	Vpeak/(m/s)	55.2	22.5	55.2	22.5	55.2	22.5	55.2	22.5	55.2	22.5
Motor Constant @25°C	K _m	N/Sqrt(W)	10.2	10.2	14.5	14.5	17.8	17.7	20.5	20.5	22.9	22.9
Resistance (L-L) @25°C ±10% ②	R ₂₅	Ω	29.00	4.85	14.50	2.43	9.67	1.62	7.25	1.21	5.80	0.97
Inductance (L-L) ±30% ③	L	mH	21.60	3.60	10.80	1.80	7.20	1.20	5.40	0.90	4.32	0.72
Electrical Time Constant	τ _e	ms	0.74	0.74	0.74	0.74	0.74	0.74	0.74	0.74	0.74	0.74
Continuous Current (NC) @110°C ①	I _{cn}	Arms	1.1	2.7	2.2	5.4	3.3	8.1	4.4	10.8	5.5	13.5
Peak Current	I _{pk}	Arms	3.8	9.3	7.6	18.6	11.4	27.9	15.2	37.2	19.0	46.5
Continuous Power Dissipation (NC) @110°C ①	P _{cn}	W	69.9	69.9	139.7	139.7	209.6	209.6	279.4	279.4	349.3	349.3
Max. Coil Temperature	T _{max}	°C	110.0	110.0	110.0	110.0	110.0	110.0	110.0	110.0	110.0	110.0
Thermal Dissipation Constant (NC) ①	K _{thn}	W/°C	0.8	0.8	1.6	1.6	2.5	2.5	3.3	3.3	4.1	4.1
Temperature Sensor	-	-	PTC/NTC	PTC/NTC	PTC/NTC	PTC/NTC	PTC/NTC	PTC/NTC	PTC/NTC	PTC/NTC	PTC/NTC	PTC/NTC
Max. Bus Voltage	U _{bus}	Vdc	330.0	330.0	330.0	330.0	330.0	330.0	330.0	330.0	330.0	330.0
Magnetic Period	τ _{NN}	mm	42.0	42.0	42.0	42.0	42.0	42.0	42.0	42.0	42.0	42.0
Attraction Force	F _a	N	0	0	0	0	0	0	0	0	0	0
Mechanical Parameters												
Coil Mass (NC) ④	m _{cn}	kg	0.24	0.24	0.49	0.49	0.69	0.69	0.91	0.91	1.14	1.14
Coil Length (NC)	L _{cn}	mm	106.0	106.0	190.0	190.0	274.0	274.0	358.0	358.0	442.0	442.0
Track Mass Per Meter	m _{track}	kg/m	11.0	11.0	11.0	11.0	11.0	11.0	11.0	11.0	11.0	11.0
Other Information												
Insulation Class	Class B (130°C)											
Protection Grade	IP00											
Compliance with Global Standards	RoHS, CE											
Ambient Temperature	Operation	0°C to 40°C (non-freezing)										
	Storage	-15°C to 70°C (non-freezing)										
Ambient Humidity	Operation	10%RH to 80%RH (non-condensing)										
	Storage	10%RH to 90%RH (non-condensing)										
Recommended Ambience	Indoor (no direct sunlight); No corrosive gas, inflammable gas, oil mist or dust.											

① Measurement is taken at ambient temperature 25°C. Value depends on the thermal environment. Abbreviations: NC-Natural Cooling.

② Resistance is measured by DC current with standard 0.5 m cable.

③ Inductance is measured by current frequency of 1 kHz.

④ Coil mass does not include hall module mass.

The contents of datasheet are subject to change without prior notice.

Dimensional Drawing

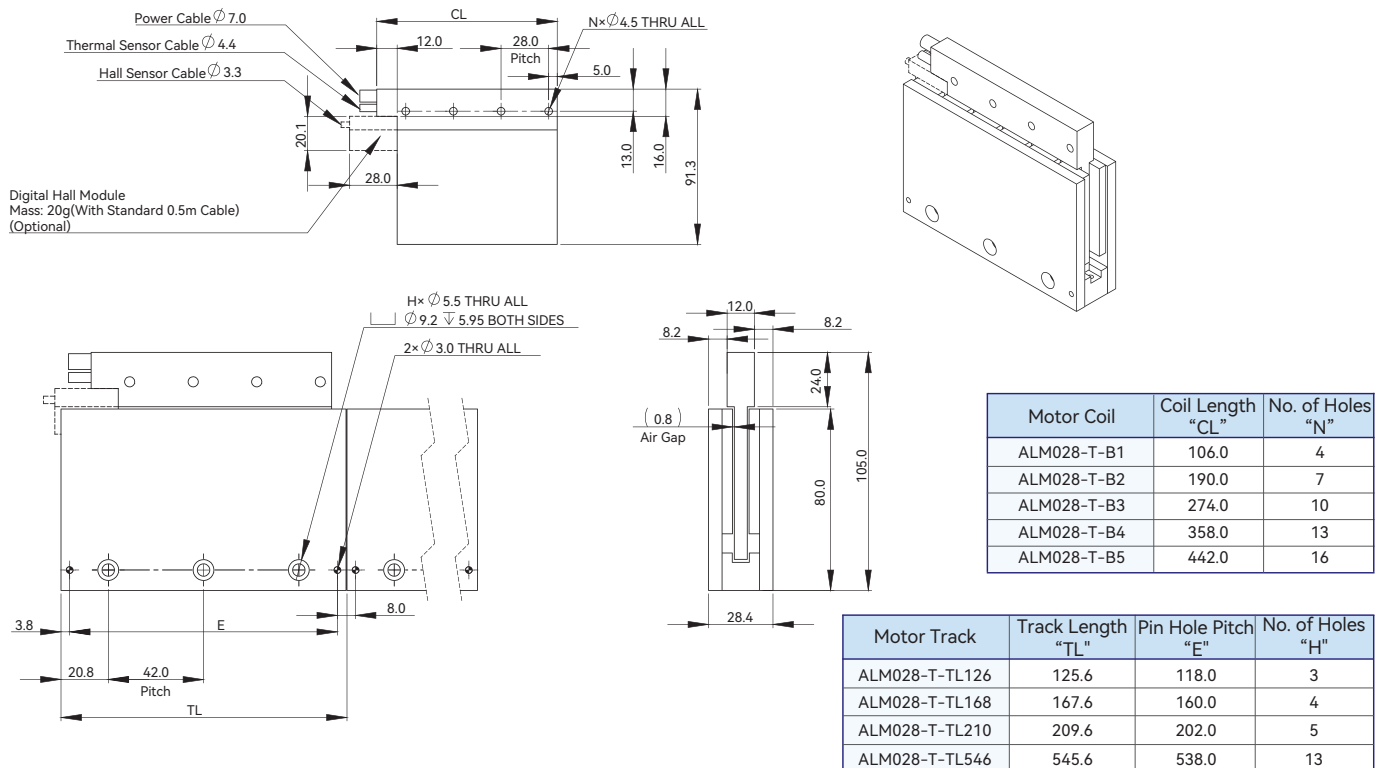

ALM-T Series

Force-Speed Curve

Introduction | Sizing Guide | Frequently Asked Questions | Linear Motors | Voice Coil Motors | Direct Drive Rotary Motors | Magnet Spring Motion Control of Gantry Stages

Akribis systems

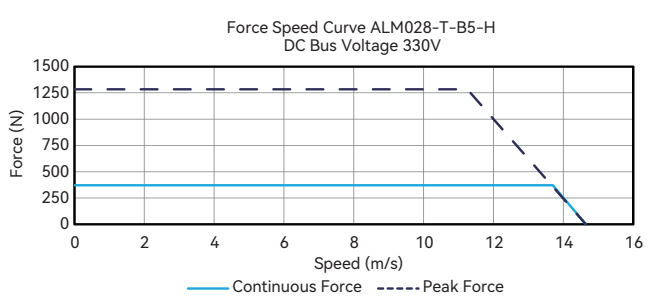
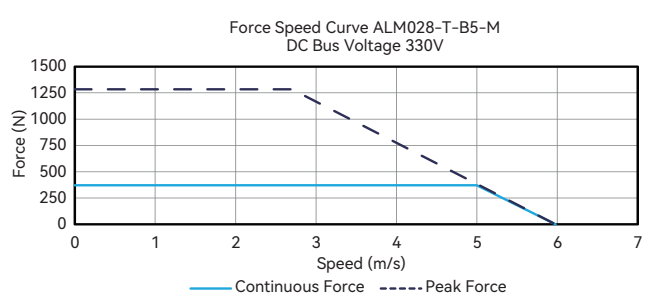
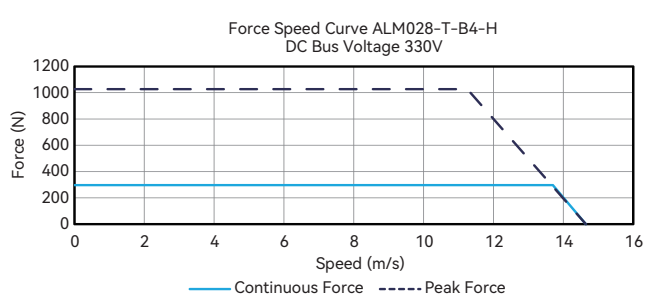
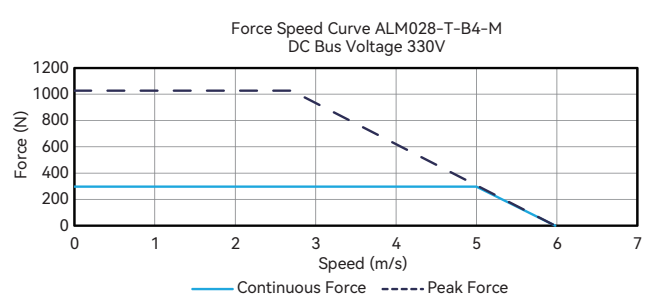
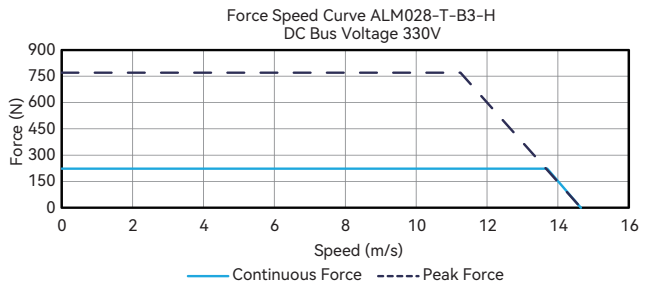
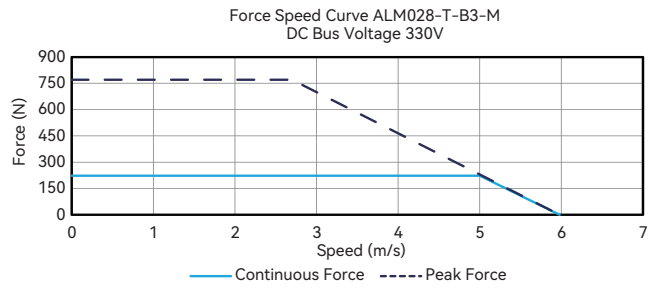
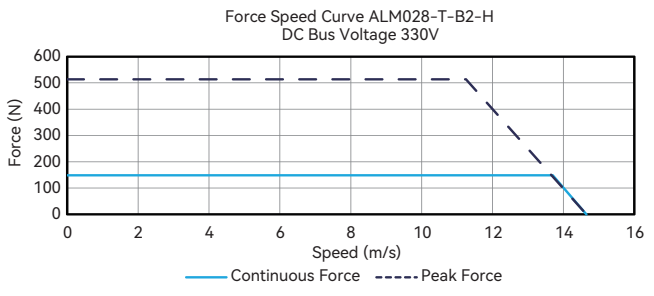
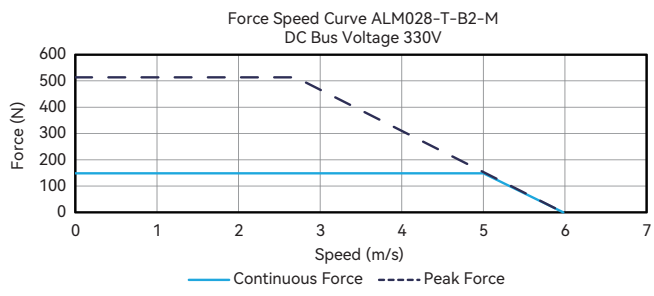
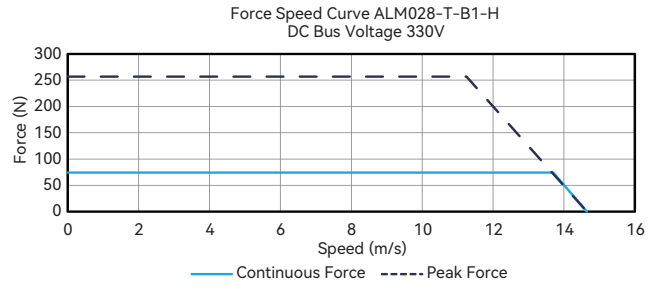
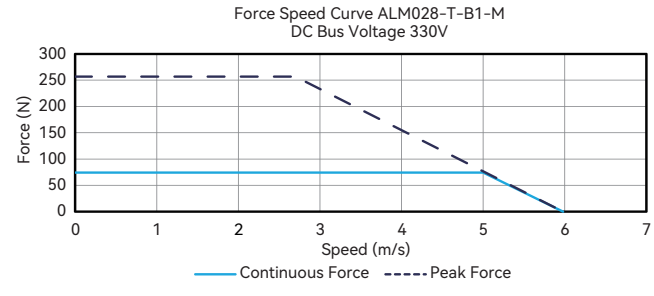

Part Numbering

Motor Coil

ALM028-T-B1-N-NP-M-NF-005-XF-000

Model:

ALM028-T

Size:

B1 / B2 / B3 / B4 / B5

Cooling Type:

N¹

Thermal Sensor:

NP²

¹ N = Natural Cooling

² NP = NTC+PTC

³ M = Mid speed winding

⁴ H = High speed winding

⁵ NF = Without Built-in Hall Sensor C/W Flying Leads

⁶ HF = With Built-in Hall Sensor & Hall Cable C/W Flying Leads

⁷ 005 = 0.5m; 030 = 3.0m

⁸ XF = Without Ferrite Bead C/W Flying Leads

(Cables with connectors can be customized, for more options, please consult cust-service@akribis-sys.com)

Design Control Code:

000

Power Cable:

XF⁸

Cable Length:

005 / 030⁷

Hall Sensor Cable:

NF / HF^{5,6}

Winding Code:

M / H^{3,4}

Motor Track

ALM028-T-TL126-TN-000

Model:

ALM028-T

Track Length:

TL126 / TL168 / TL210 / TL546

¹ TN = Standard Track, No Cover

Design Control Code:

000

Track Type:

TN¹

ALM038-T

Performance Parameters	Symbol	Unit	ALM038-T-B1		ALM038-T-B2		ALM038-T-B3		ALM038-T-B4		ALM038-T-B6
			M	H	M	H	M	H	M	H	M
Continuous Force (NC) @110°C	F_{cn}	N	125.1	125.1	250.2	250.2	375.3	375.3	500.4	500.4	750.6
Peak Force	F_{pk}	N	622.7	622.7	1245.4	1245.4	1868.2	1868.2	2490.9	2490.9	3736.3
Force Constant $\pm 10\%$	K_f	N/Arms	111.2	45.0	111.2	45.0	111.2	45.0	111.2	45.0	111.2
Back EMF Constant $\pm 10\%$	K_e	Vpeak/(m/s)	90.8	36.7	90.8	36.7	90.8	36.7	90.8	36.7	90.8
Motor Constant @25°C	K_m	N/Sqrt(W)	16.7	16.7	23.6	23.6	28.9	28.9	33.4	33.4	40.9
Resistance (L-L) @25°C $\pm 10\%$	R_{25}	Ω	29.56	4.84	14.78	2.42	9.85	1.61	7.39	1.21	4.93
Inductance (L-L) $\pm 30\%$	L	mH	44.60	7.30	22.30	3.65	14.87	2.43	11.15	1.83	7.43
Electrical Time Constant	τ_e	ms	1.51	1.51	1.51	1.51	1.51	1.51	1.51	1.51	1.51
Continuous Current (NC) @110°C	I_{cn}	Arms	1.1	2.8	2.3	5.6	3.4	8.3	4.5	11.1	6.7
Peak Current	I_{pk}	Arms	5.6	13.8	11.2	27.7	16.8	41.5	22.4	55.4	33.6
Continuous Power Dissipation (NC) @110°C	P_{cn}	W	74.5	74.5	149.0	149.0	223.4	223.4	297.9	297.9	445.6
Max. Coil Temperature	T_{max}	°C	110.0	110.0	110.0	110.0	110.0	110.0	110.0	110.0	110.0
Thermal Dissipation Constant (NC)	K_{thn}	W/°C	0.9	0.9	1.8	1.8	2.6	2.6	3.5	3.5	5.2
Temperature Sensor	-	-	PTC/NTC	PTC/NTC	PTC/NTC	PTC/NTC	PTC/NTC	PTC/NTC	PTC/NTC	PTC/NTC	PTC/NTC
Max. Bus Voltage	U_{bus}	Vdc	330.0	330.0	330.0	330.0	330.0	330.0	330.0	330.0	330.0
Magnetic Period	T_{NN}	mm	57.0	57.0	57.0	57.0	57.0	57.0	57.0	57.0	57.0
Attraction Force	F_a	N	0	0	0	0	0	0	0	0	0
Mechanical Parameters											
Coil Mass (NC)	m_{cn}	kg	0.54	0.54	1.05	1.05	1.58	1.58	2.12	2.12	3.10
Coil Length (NC)	L_{cn}	mm	134.0	134.0	248.0	248.0	362.0	362.0	476.0	476.0	704.0
Track Mass Per Meter	m_{track}	kg/m	18.6	18.6	18.6	18.6	18.6	18.6	18.6	18.6	18.6
Other Information											
Insulation Class	Class B (130°C)										
Protection Grade	IP00										
Compliance with Global Standards	RoHS, CE										
Ambient Temperature	Operation	0°C to 40°C (non-freezing)									
	Storage	-15°C to 70°C (non-freezing)									
Ambient Humidity	Operation	10%RH to 80%RH (non-condensing)									
	Storage	10%RH to 90%RH (non-condensing)									
Recommended Ambience	Indoor (no direct sunlight); No corrosive gas, inflammable gas, oil mist or dust.										

① Measurement is taken at ambient temperature 25°C. Value depends on the thermal environment. Abbreviations: NC-Natural Cooling.

② Resistance is measured by DC current with standard 0.5 m cable.

③ Inductance is measured by current frequency of 1 kHz.

④ Coil mass does not include hall module mass.

The contents of datasheet are subject to change without prior notice.

Dimensional Drawing

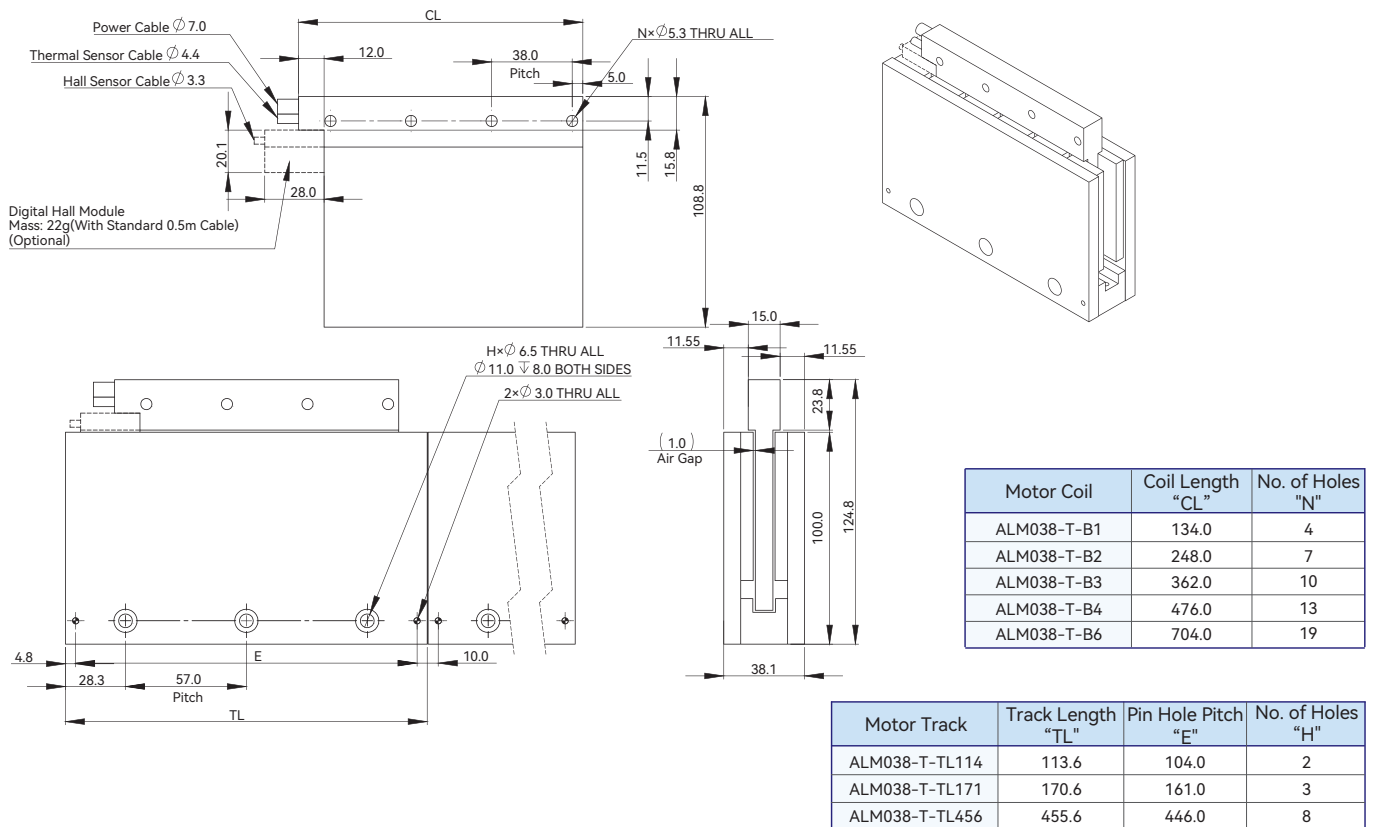

Force-Speed Curve

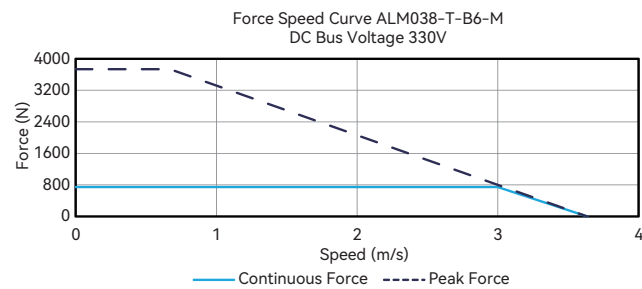
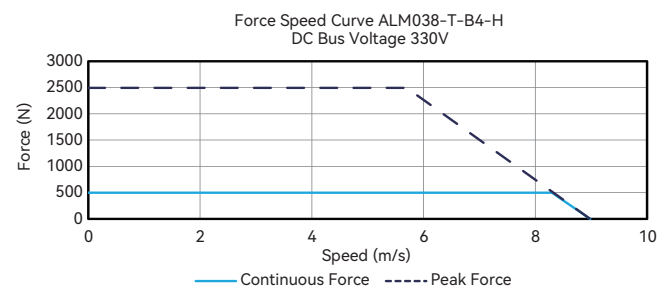
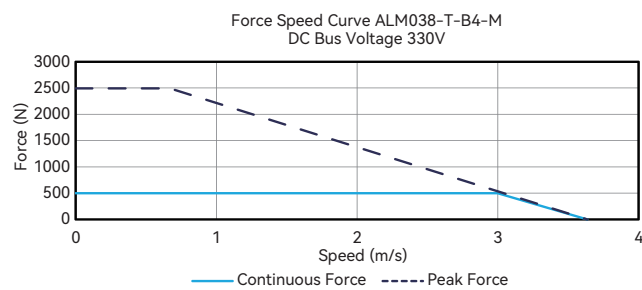
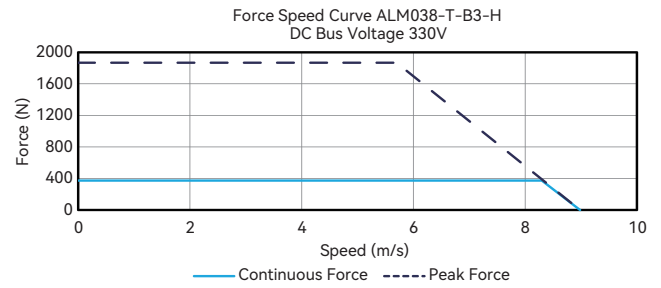
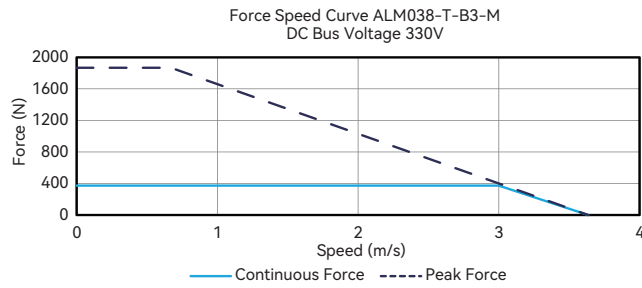
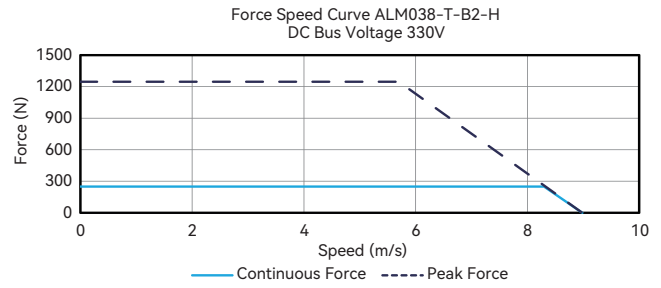
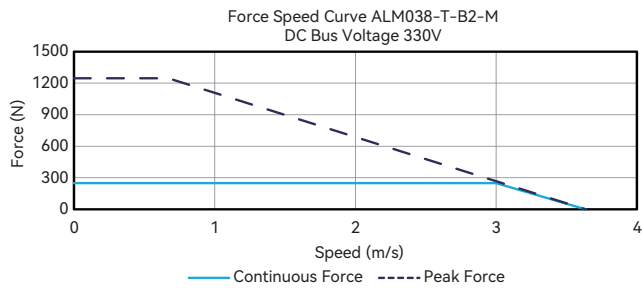
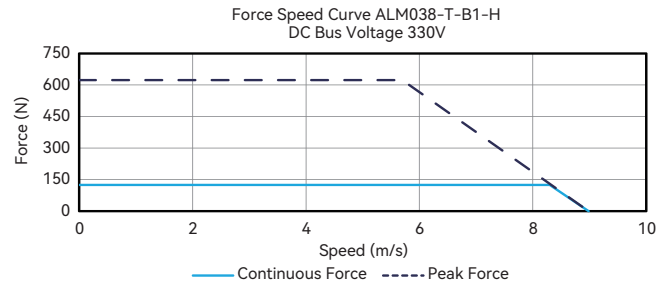
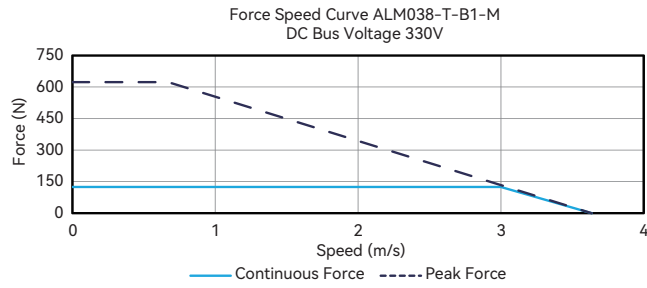

Part Numbering

Motor Coil

ALM038-T-B1-N-NP-M-NF-005-XF-000

Model:

ALM038-T

Size:

B1 / B2 / B3 / B4 / B6

Cooling Type:

N¹

Thermal Sensor:

NP²

Design Control Code:

000

Power Cable:

XF³

Cable Length:

005 / 030⁴

Hall Sensor Cable:

NF / HF⁵

Winding Code:

M / H⁶

- ¹ N = Natural Cooling
- ² NP = NTC+PTC
- ³ M = Mid speed winding
- ⁴ H = High speed winding
- ⁵ NF = Without Built-in Hall Sensor C/W Flying Leads
- ⁶ HF = With Built-in Hall Sensor & Hall Cable C/W Flying Leads
- ⁷ 005 = 0.5m; 030 = 3.0m
- ⁸ XF = Without Ferrite Bead C/W Flying Leads
(Cables with connectors can be customized, for more options, please consult cust-service@akribis-sys.com)

Motor Track

ALM038-T-TL114-TN-000

Model:

ALM038-T

Track Length:

TL114 / TL171 / TL456

¹ TN = Standard Track, No Cover

Design Control Code:

000

Track Type:

TN¹

ALM-T Series

Force-Speed Curve

Force Speed Curve ALM048-T-B1-M
DC Bus Voltage 330V

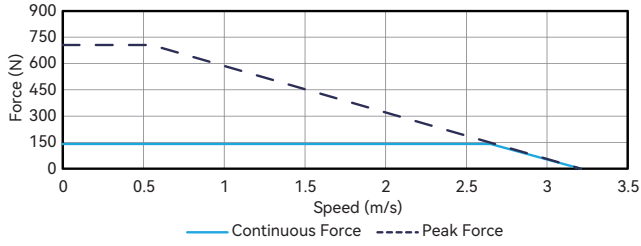

Force Speed Curve ALM048-T-B1-H
DC Bus Voltage 330V

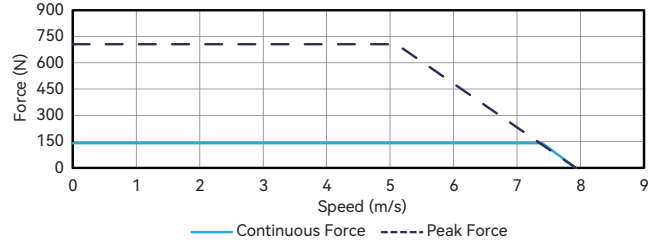

Force Speed Curve ALM048-T-B2-M
DC Bus Voltage 330V

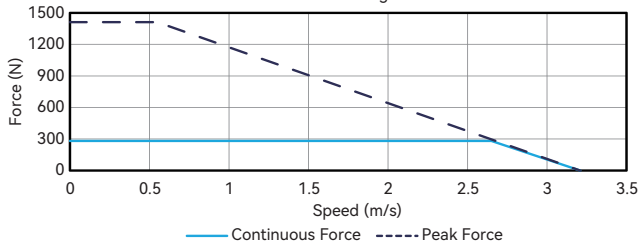

Force Speed Curve ALM048-T-B2-H
DC Bus Voltage 330V

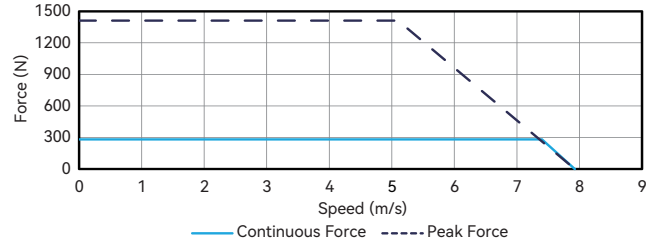

Force Speed Curve ALM048-T-B3-M
DC Bus Voltage 330V

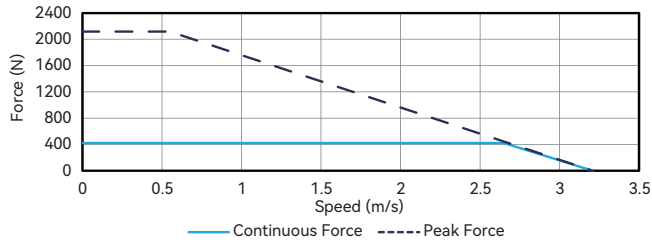

Force Speed Curve ALM048-T-B3-H
DC Bus Voltage 330V

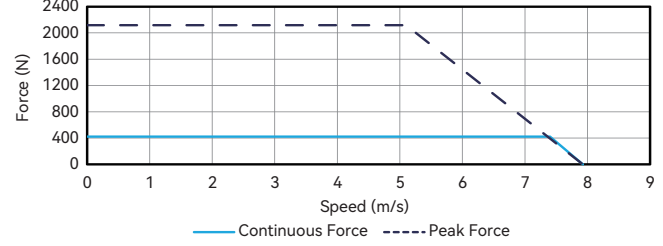

Force Speed Curve ALM048-T-B4-M
DC Bus Voltage 330V

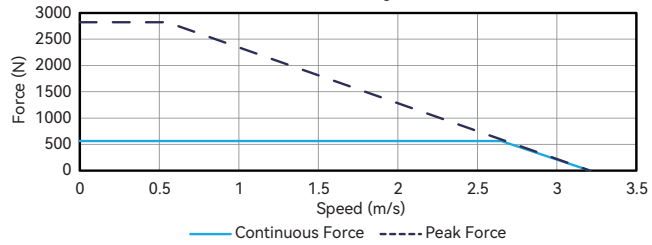

Force Speed Curve ALM048-T-B4-H
DC Bus Voltage 330V

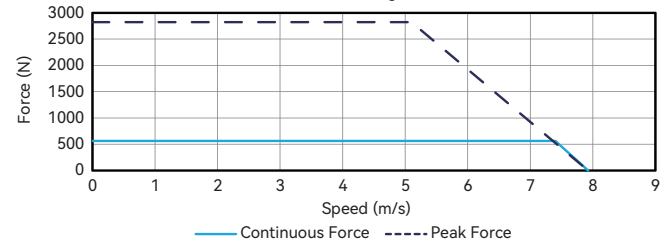

Force Speed Curve ALM048-T-B6-M
DC Bus Voltage 330V

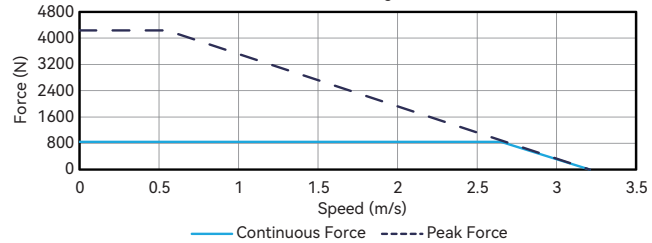

Introduction Sizing Guide Frequently Asked Questions Linear Motors Voice Coil Motors Direct Drive Rotary Motors Magnet Spring Motion Control of Gantry Stages

Part Numbering

Motor Coil

ALM048-T-B1-N-NP-M-NF-005-XF-000

Model:

ALM048-T

Size:

B1 / B2 / B3 / B4 / B6

Cooling Type:

N

Thermal Sensor:

NP

1 N = Natural Cooling

2 NP = NTC+PTC

3 M = Mid speed winding

4 H = High speed winding

5 NF = Without Built-in Hall Sensor C/W Flying Leads

6 HF = With Built-in Hall Sensor & Hall Cable C/W Flying Leads

7 005 = 0.5m; 030 = 3.0m

8 XF = Without Ferrite Bead C/W Flying Leads

(Cables with connectors can be customized, for more options, please consult cust-service@akribis-sys.com)

Design Control Code:

000

Power Cable:

XF

Cable Length:

005 / 030

Hall Sensor Cable:

NF / HF

Winding Code:

M / H

Motor Track

ALM048-T-TL114-TN-000

Model:

ALM048-T

Track Length:

TL114 / TL171 / TL456

9 TN = Standard Track, No Cover

Design Control Code:

000

Track Type:

TN

ALM015 / 016-T Series Motor Cable Connection

Introduction | Sizing Guide | Frequently Asked Questions | Linear Motors | Voice Coil Motors | Direct Drive Rotary Motors | Magnet Spring Motion Control of Gantry Stages

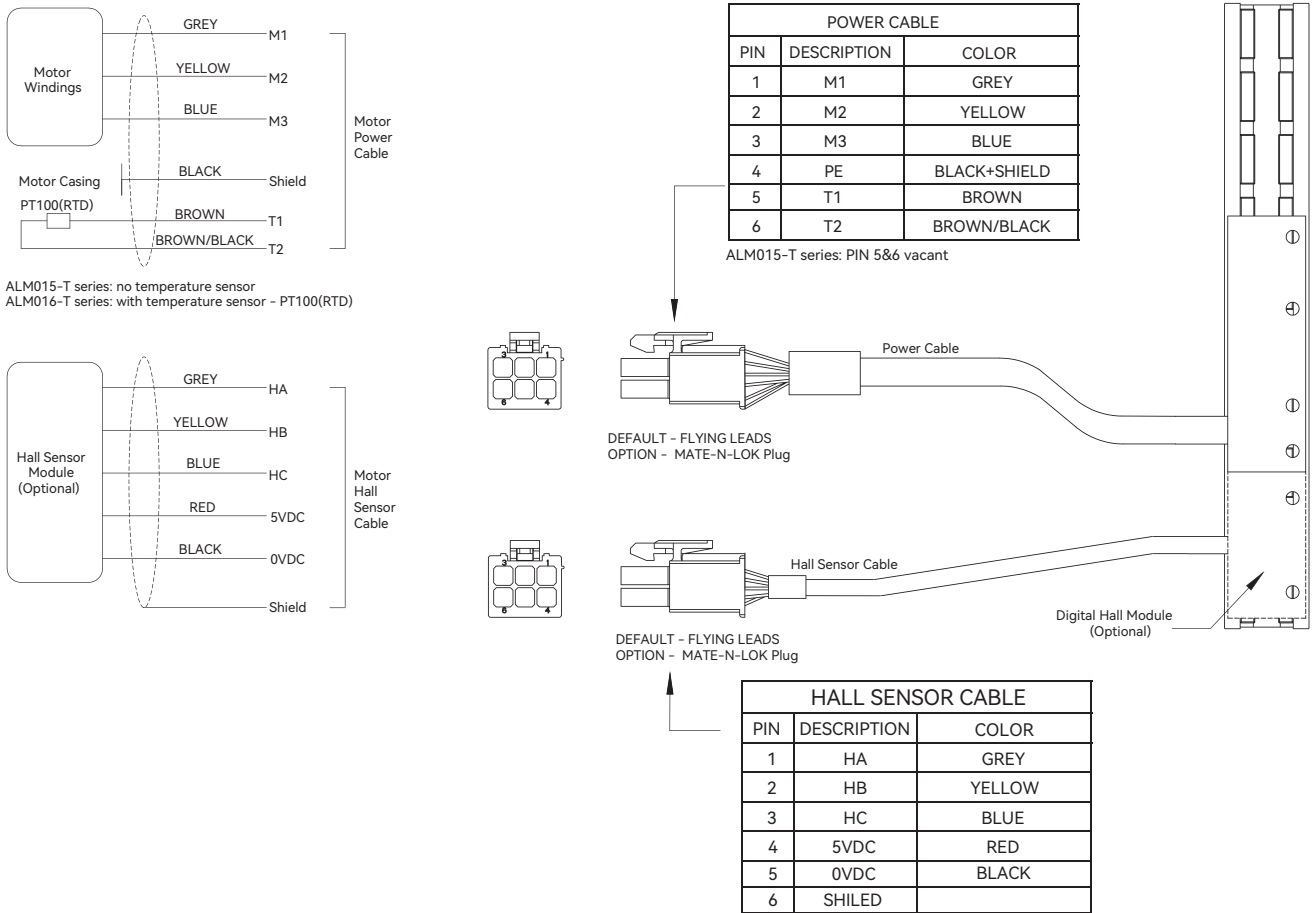

ALM021-T Series Motor Cable Connection

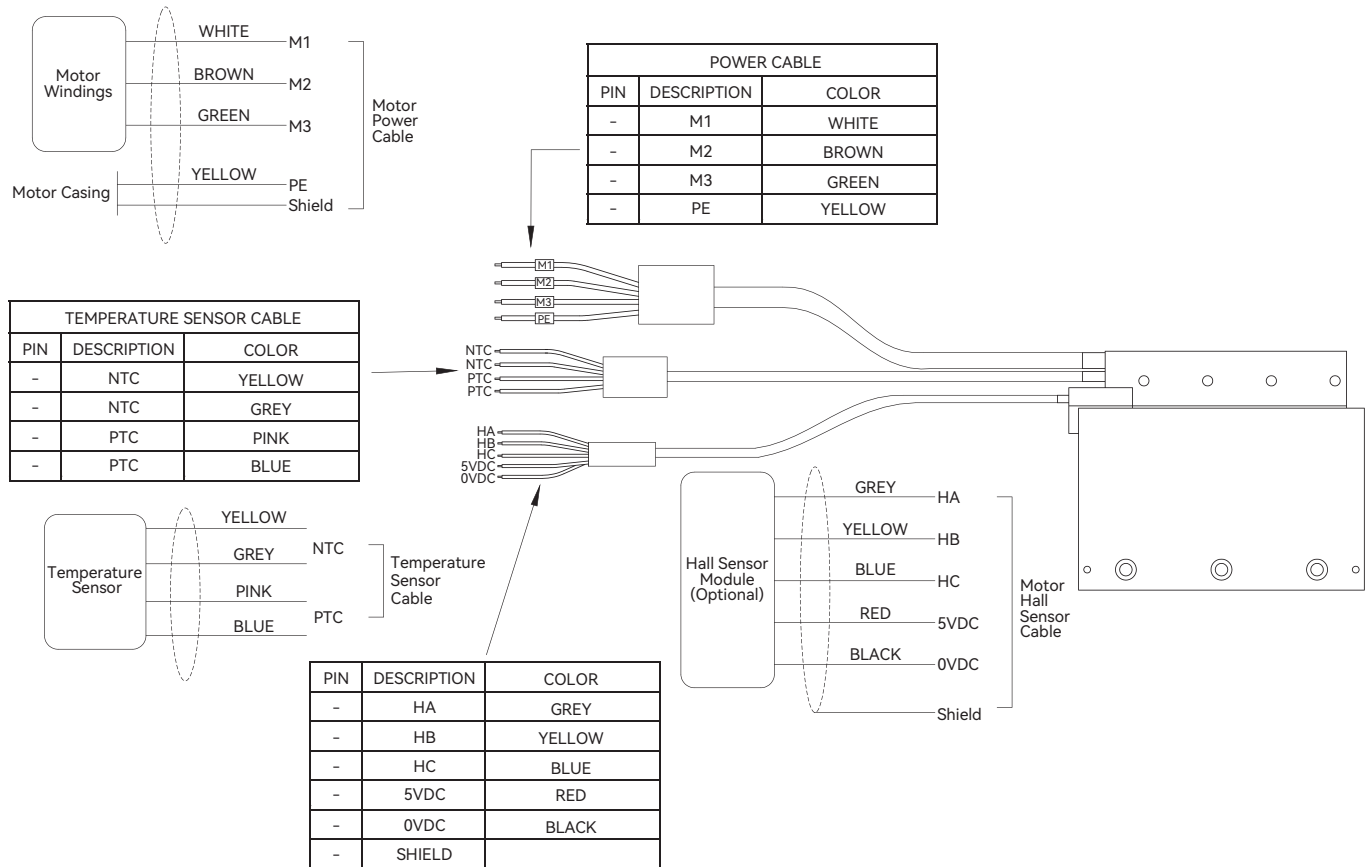

ALM028 / 038 / 048-T Series Motor Cable Connection

