

AWM SERIES

- ▶ Ironless technology
- ▶ Vacuum Compatible (RGA tested)
- ▶ Zero cogging force
- ▶ High Motor Constant
- ▶ High continuous force and peak force

EN-26.3.1

Introduction

AWM series linear motors are vacuum compatible ironless motors with no cogging force and high continuous/peak forces.

Continuous Force $F_{cn} = 4.5\text{N}-769.1\text{N}$

Peak Force $F_{pk} = 22.3\text{N}-3845.3\text{N}$

Features

- ▶ Vacuum compatible (RGA tested in 1×10^{-7} Torr vacuum)
- ▶ Ironless technology and no cogging force
- ▶ High continuous and peak force
- ▶ High motor constant
- ▶ Multiple coil lengths to select

Applications

Applicable to point-to-point micron/nanometer level positioning; unlimited travel stroke with top speed of 5m/s or faster; low velocity ripple during both fast and low speed scanning; precise force control with fine resolution.

Applications & Industries: front-end & back-end wafer handling and inspection, glass and LCD applications, and biomedical applications that require vacuum compatibility, high speed, precise motion and velocity control.

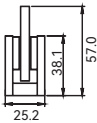
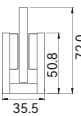
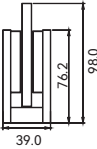
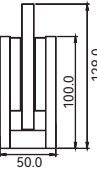
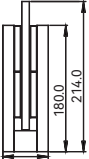
	Series	Coil Length (mm)	● Continuous Force (F_{cn}) / ■ PeakForce (F_{pk}) ^①						Unit: N
			5	105	205	305	405	505
	AWM1-S1	43	● 4.5 / ■ 22.3						
	AWM1-S2	85	● 8.9 / ■ 44.7						
	AWM1-S3	127	● 13.4 / ■ 67.0						
	AWM2-S1	61	● 13.5 / ■ 67.4						
	AWM2-S2	121	● 27.0 / ■ 134.9						
	AWM2-S3	181	● 40.5 / ■ 202.3						
	AWM3-S1	121	● 47.0 / ■ 240.1						
	AWM3-S2	241	● 94.0 / ■ 480.2						
	AWM3-S3	361	● 140.9 / ■ 720.4						
	AWM4-S1	121	● 79.6 / ■ 397.9						
	AWM4-S2	241	● 159.2 / ■ 795.8						
	AWM4-S3	361	● 238.7 / ■ 1193.7						
	AWM5-S1	169	● 138.3 / ■ 995.4						
	AWM5-S2	337	● 276 / ■ 1990.9						
	AWM5-S3	505	● 414.8 / ■ 2986.3						
	AWM6-S1	169	● 256.4 / ■ 1281.8						
	AWM6-S2	337	● 512.7 / ■ 2563.5						
	AWM6-S3	505	● 769.1 / ■ 3845.3						

① Continuous force is measured under the condition of self-cooling.

AWM1

			AWM1-S1	AWM1-S2	AWM1-S3
Performance Parameters			Series	Series	Series
Continuous Force (NC) @100°C ①	F _{cn}	N	4.5	8.9	13.4
Peak Force	F _{pk}	N	22.3	44.7	67.0
Force Constant ±10%	K _f	N/Arms	2.6	5.3	7.9
Back EMF Constant ±10%	K _e	V _{peak} /(m/s)	2.1	4.3	6.4
Motor Constant @25°C	K _m	N/Sqrt(W)	1.9	2.7	3.3
Resistance (L-L) 25°C ±10% ②	R ₂₅	Ω	1.3	2.5	3.75
Inductance (L-L) ±30% ③	L	mH	0.2	0.4	0.6
Electrical Time Constant	τ _e	ms	0.2	0.2	0.2
Continuous Current (NC) @100°C ①	I _{cn}	Arms	1.7	1.7	1.7
Peak Current	I _{pk}	Arms	8.5	8.5	8.5
Continuous Power Dissipation (NC) @100°C ①	P _{cn}	W	7.0	14.0	21.0
Max. Coil Temperature	t _{max}	°C	125.0	125.0	125.0
Thermal Dissipation Constant (NC) ①	K _{thn}	W/°C	0.1	0.2	0.3
Max. Bus Voltage	U _{bus}	V _{dc}	330.0	330.0	330.0
Magnetic Period	T _{NN}	mm	21.0	21.0	21.0
Attraction Force	F _a	kN	0.0	0.0	0.0
Mechanical Parameters					
Coil Mass (NC)	m _{cn}	kg	0.02	0.04	0.06
Coil Length (NC)	L _{cn}	mm	43.0	85.0	127.0
Track Mass Per Meter	m _{track}	kg/m	2.9	2.9	2.9
Other Information					
Insulation Class	Class B (130°C)				
Protection Grade	IP00				
Compliance with Global Standards	RoHS, CE				
Ambient Temperature	Operation	0°C to 40°C (non-freezing)			
	Storage	-15°C to 70°C (non-freezing)			
Ambient Humidity	Operation	10%RH to 80%RH (non-condensing)			
	Storage	10%RH to 90%RH (non-condensing)			
Recommended Ambience	Indoor (no direct sunlight); No corrosive gas, inflammable gas, oil mist or dust.				

① Measurement is taken at ambient temperature 25°C. Value depends on the thermal environment.

② Resistance is measured by DC current with standard 0.5 m cable.

③ Inductance is measured by current frequency of 1 kHz.

The contents of datasheet are subject to change without prior notice.

Dimension

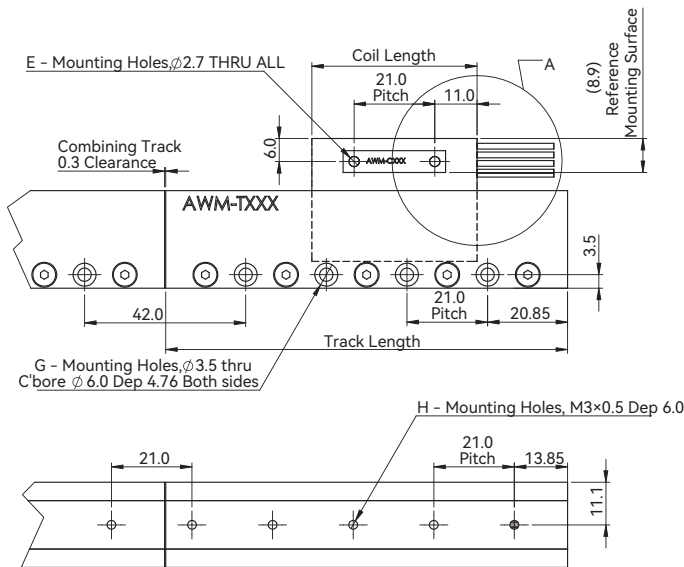

Motor Coil		
Model No	Coil Length	E
AWM1-S1	43.0	2
AWM1-S2	85.0	4
AWM1-S3	127.0	6

Motor Track			
Model No	Track Length	G	H
AWM1-TL63	62.7	2	3
AWM1-TL84	83.7	3	4
AWM1-TL105	104.7	4	5

Force-Speed Curve

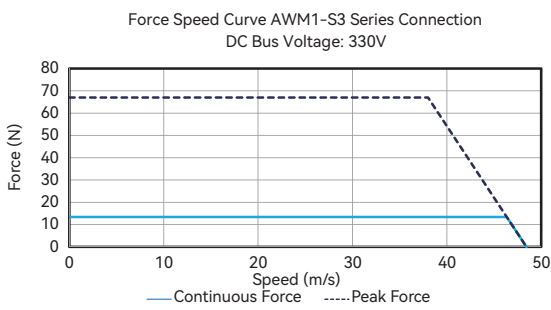
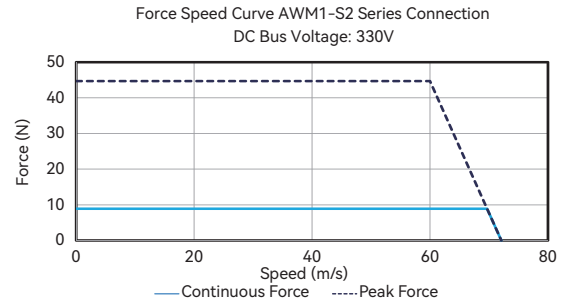
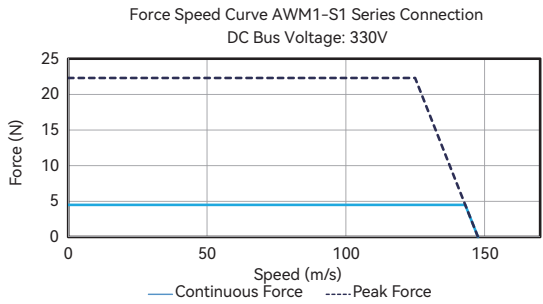

Part Numbering

Motor Coil

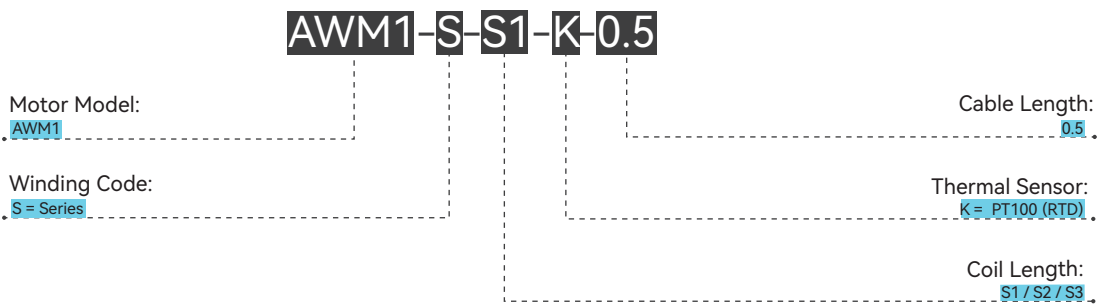

Motor Track



AWM2

			AWM2-S1	AWM2-S2		AWM2-S3	
Performance Parameters	Symbol	Unit	Series	Series	Parallel	Series	Parallel
Continuous Force (NC) @100°C ①	F_{cn}	N	13.5	27.0	27.0	40.5	40.5
Peak Force	F_{pk}	N	67.4	134.9	134.9	202.3	202.3
Force Constant $\pm 10\%$	K_f	N/Arms	8.4	16.9	8.4	25.3	12.6
Back EMF Constant $\pm 10\%$	K_e	Vpeak/(m/s)	6.9	13.8	6.9	20.6	10.3
Motor Constant @25°C	K_m	N/Sqrt(W)	3.5	4.9	4.9	6.0	9.1
Resistance (L-L) 25°C $\pm 10\%$ ②	R_{25}	Ω	3.9	7.8	2.0	11.7	1.3
Inductance (L-L) $\pm 30\%$ ③	L	mH	1.3	2.6	0.7	3.9	0.4
Electrical Time Constant	τ_e	ms	0.3	0.3	0.3	0.3	0.3
Continuous Current (NC) @100°C ①	I_{cn}	Arms	1.6	1.6	3.2	1.6	3.2
Peak Current	I_{pk}	Arms	8.0	8.0	16.0	8.0	16.0
Continuous Power Dissipation (NC) @100°C ①	P_{cn}	W	19.3	38.6	38.6	57.9	25.7
Max. Coil Temperature	t_{max}	°C	125.0	125.0	125.0	125.0	125.0
Thermal Dissipation Constant (NC) ①	K_{thn}	W/°C	0.3	0.5	0.5	0.8	0.3
Max. Bus Voltage	U_{bus}	Vdc	330.0	330.0	330.0	330.0	330.0
Magnetic Period	T_{MN}	mm	30.0	30.0	30.0	30.0	30.0
Attraction Force	F_a	kN	0.0	0.0	0.0	0.0	0.0
Mechanical Parameters							
Coil Mass (NC)	m_{cn}	kg	0.06	0.13	0.13	0.19	0.19
Coil Length (NC)	L_{cn}	mm	61.0	121.0	121.0	181.0	181.0
Track Mass Per Meter	m_{track}	kg/m	4.9	4.9	4.9	4.9	4.9
Other Information							
Insulation Class			Class B (130°C)				
Protection Grade			IP00				
Compliance with Global Standards			RoHS, CE				
Ambient Temperature	Operation	0°C to 40°C (non-freezing)					
	Storage	-15°C to 70°C (non-freezing)					
Ambient Humidity	Operation	10%RH to 80%RH (non-condensing)					
	Storage	10%RH to 90%RH (non-condensing)					
Recommended Ambience			Indoor (no direct sunlight); No corrosive gas, inflammable gas, oil mist or dust.				

① Measurement is taken at ambient temperature 25°C. Value depends on the thermal environment.

② Resistance is measured by DC current with standard 0.5 m cable.

③ Inductance is measured by current frequency of 1 kHz.

The contents of datasheet are subject to change without prior notice.

Dimension

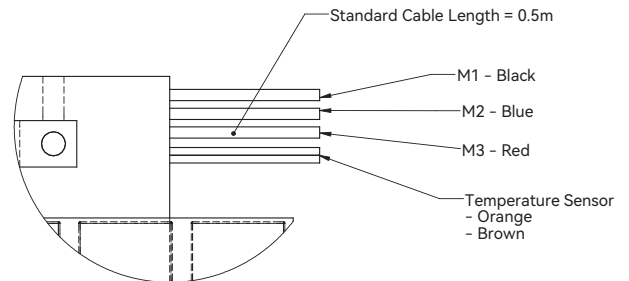
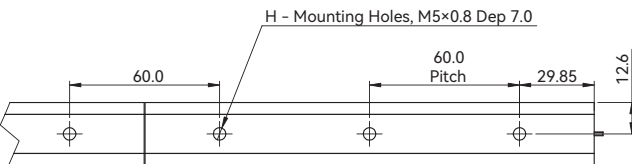
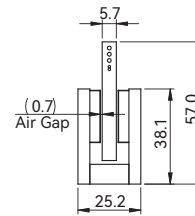
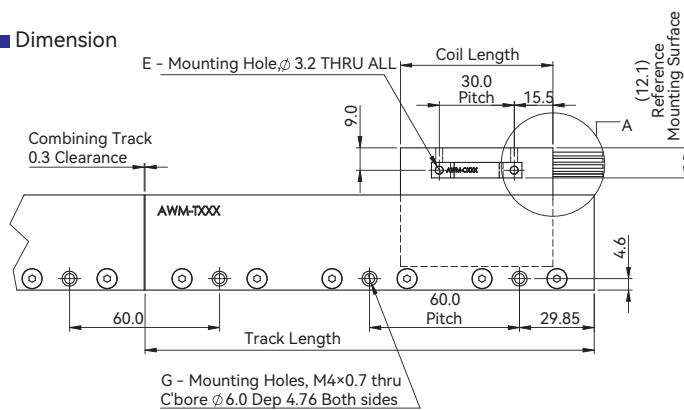

Motor Coil		
Model No	Coil Length	E
AWM2-S1	61.0	2
AWM2-S2	121.0	4
AWM2-S3	181.0	6

Motor Track			
Model No	Track Length	G	H
AWM2-TL120	119.7	2	2
AWM2-TL180	179.7	3	3
AWM2-TL240	239.7	4	4
AWM2-TL300	299.7	5	5

Force-Speed Curve

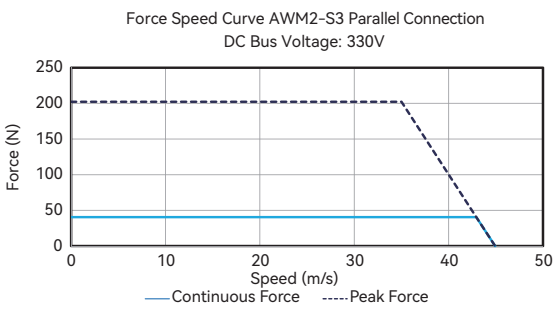
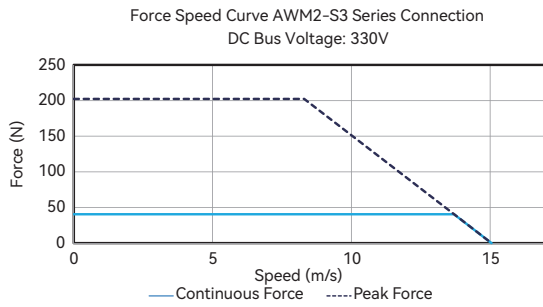
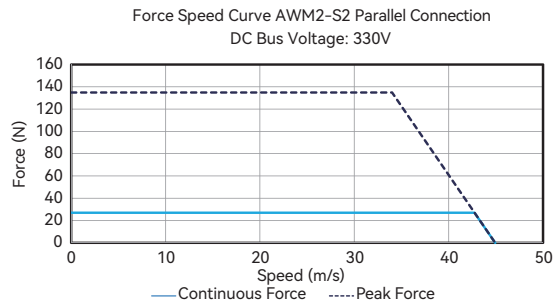
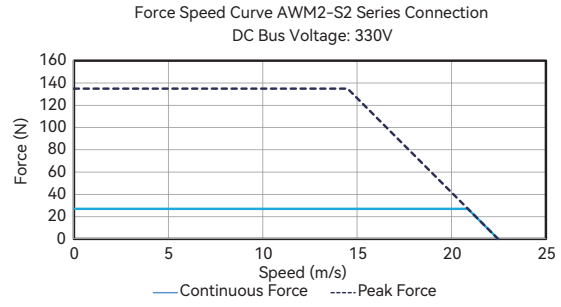
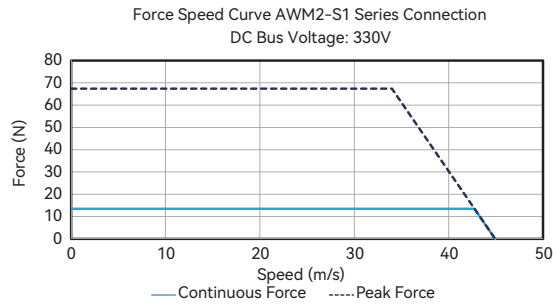

Part Numbering

Motor Coil

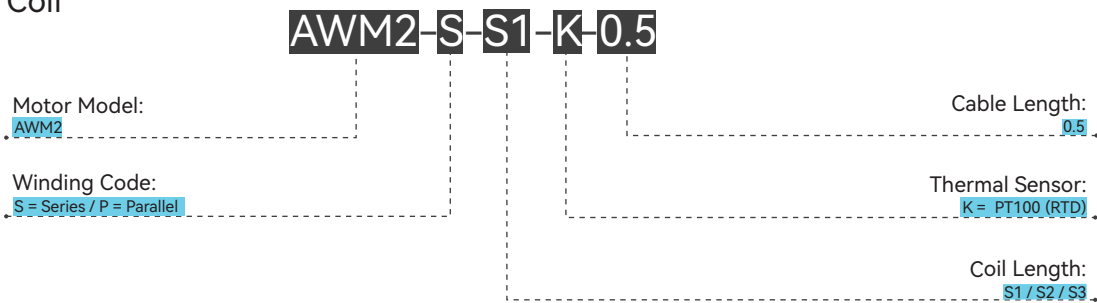

Motor Track

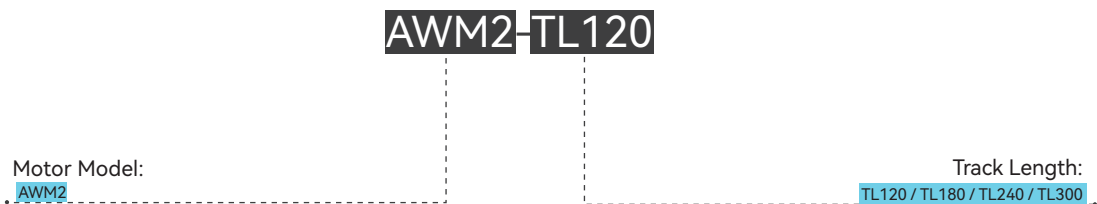

AWM3

			AWM3-S1	AWM3-S2		AWM3-S3	
Performance Parameters	Symbol	Unit	Series	Series	Parallel	Series	Parallel
Continuous Force (NC) @100°C ①	F _{cn}	N	47.0	94.0	94.0	140.9	140.9
Peak Force	F _{pk}	N	240.1	480.2	480.2	720.4	720.4
Force Constant ±10%	K _f	N/Arms	26.1	52.2	26.1	78.3	26.1
Back EMF Constant ±10%	K _e	Vpeak/(m/s)	21.3	42.6	21.3	63.9	21.3
Motor Constant @25°C	K _m	N/Sqrt(W)	7.7	10.9	10.9	13.3	13.3
Resistance (L-L) 25°C ±10% ②	R ₂₅	Ω	7.7	15.4	3.9	23.1	2.6
Inductance (L-L) ±30% ③	L	mH	5.9	11.8	3.0	17.7	2.0
Electrical Time Constant	τ _e	ms	0.8	0.8	0.8	0.8	0.8
Continuous Current (NC) @100°C ①	I _{cn}	Arms	1.8	1.8	3.6	1.8	5.4
Peak Current	I _{pk}	Arms	9.2	9.2	18.4	9.2	27.6
Continuous Power Dissipation (NC) @100°C ①	P _{cn}	W	48.2	96.5	96.5	178.4	178.4
Max. Coil Temperature	t _{max}	°C	125.0	125.0	125.0	125.0	125.0
Thermal Dissipation Constant (NC) ①	K _{thn}	W/°C	0.6	1.3	1.3	2.4	2.4
Max. Bus Voltage	U _{bus}	Vdc	330.0	330.0	330.0	330.0	330.0
Magnetic Period	τ _{NN}	mm	60.0	60.0	60.0	60.0	60.0
Attraction Force	F _a	kN	0.0	0.0	0.0	0.0	0.0
Mechanical Parameters							
Coil Mass (NC)	m _{cn}	kg	0.24	0.48	0.48	0.71	0.71
Coil Length (NC)	L _{cn}	mm	121.0	241.0	241.0	361.0	361.0
Track Mass Per Meter	m _{track}	kg/m	8.75	8.75	8.75	8.75	8.75
Other Information							
Insulation Class	Class B (130°C)						
Protection Grade	IP00						
Compliance with Global Standards	RoHS, CE						
Ambient Temperature	Operation	0°C to 40°C (non-freezing)					
	Storage	-15°C to 70°C (non-freezing)					
Ambient Humidity	Operation	10%RH to 80%RH (non-condensing)					
	Storage	10%RH to 90%RH (non-condensing)					
Recommended Ambience	Indoor (no direct sunlight); No corrosive gas, inflammable gas, oil mist or dust.						

① Measurement is taken at ambient temperature 25°C. Value depends on the thermal environment.

② Resistance is measured by DC current with standard 0.5 m cable.

③ Inductance is measured by current frequency of 1 kHz.

The contents of datasheet are subject to change without prior notice.

Dimension

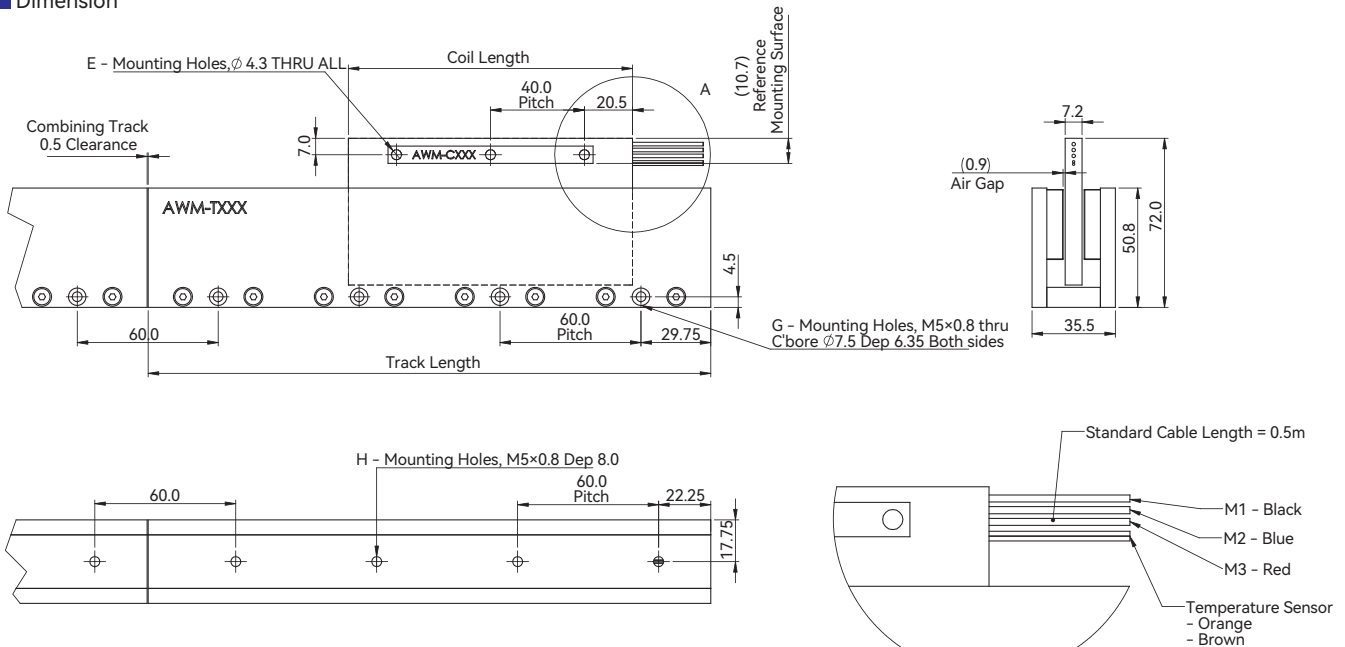

DETAIL A
SCALE 2 : 1.5

Motor Coil		
Model No	Coil Length	E
AWM3-S1	121.0	3
AWM3-S2	241.0	6
AWM3-S3	361.0	9

Motor Track			
Model No	Track Length	G	H
AWM3-TL180	179.5	3	3
AWM3-TL240	239.5	4	4
AWM3-TL300	299.5	5	5
AWM3-TL600	599.5	10	10

Force-Speed Curve

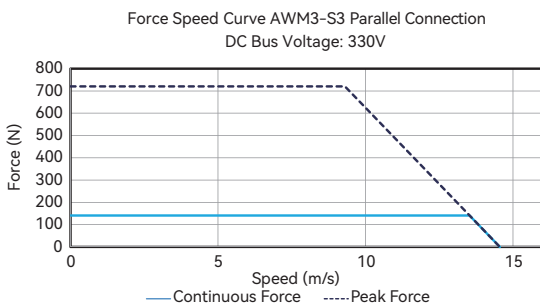
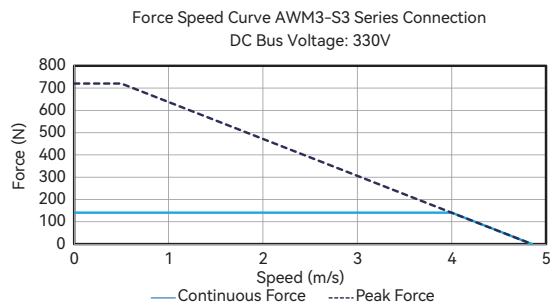
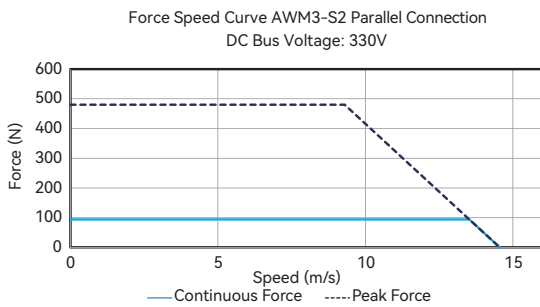
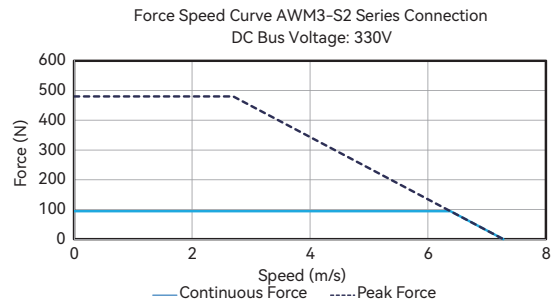
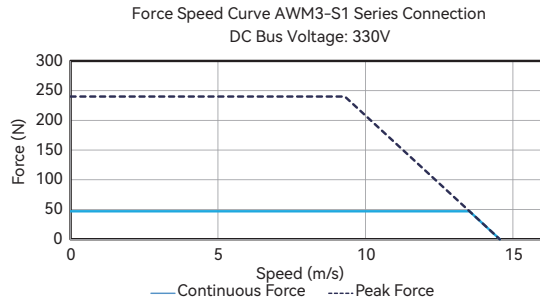

Part Numbering

Motor Coil



Motor Track



AWM4

			AWM4-S1	AWM4-S2		AWM4-S3	
Performance Parameters	Symbol	Unit	Series	Series	Parallel	Series	Parallel
Continuous Force (NC) @100°C ①	F _{cn}	N	79.6	159.2	159.2	238.7	238.7
Peak Force	F _{pk}	N	397.9	795.8	795.8	1193.7	1193.7
Force Constant ±10%	K _f	N/Arms	34.6	69.2	34.6	103.8	51.9
Back EMF Constant ±10%	K _e	Vpeak/(m/s)	28.3	56.5	28.3	84.8	42.4
Motor Constant @25°C	K _m	N/Sqrt(W)	12.0	17.0	17.0	20.9	31.3
Resistance (L-L) 25°C ±10% ②	R ₂₅	Ω	5.5	11.0	2.8	16.5	1.8
Inductance (L-L) ±30% ③	L	mH	5.7	11.4	2.9	17.1	1.9
Electrical Time Constant	τ _e	ms	1.0	1.0	1.0	1.0	1.0
Continuous Current (NC) @100°C ①	I _{cn}	Arms	2.3	2.3	4.6	2.3	4.6
Peak Current	I _{pk}	Arms	11.5	11.5	23.0	11.5	23.0
Continuous Power Dissipation (NC) @100°C ①	P _{cn}	W	56.2	112.5	112.5	168.7	75.0
Max. Coil Temperature	t _{max}	°C	125.0	125.0	125.0	125.0	125.0
Thermal Dissipation Constant (NC) ①	K _{thn}	W/°C	0.7	1.5	1.5	2.2	1.0
Max. Bus Voltage	U _{bus}	V _{dc}	330.0	330.0	330.0	330.0	330.0
Magnetic Period	T _{NN}	mm	60.0	60.0	60.0	60.0	60.0
Attraction Force	F _a	kN	0.0	0.0	0.0	0.0	0.0
Mechanical Parameters							
Coil Mass (NC)	m _{cn}	kg	0.34	0.68	0.68	1.01	1.01
Coil Length (NC)	L _{cn}	mm	121.0	241.0	241.0	361.0	361.0
Track Mass Per Meter	m _{track}	kg/m	14.72	14.72	14.72	14.72	14.72
Other Information							
Insulation Class	Class B (130°C)						
Protection Grade	IP00						
Compliance with Global Standards	RoHS, CE						
Ambient Temperature	Operation	0°C to 40°C (non-freezing)					
	Storage	-15°C to 70°C (non-freezing)					
Ambient Humidity	Operation	10%RH to 80%RH (non-condensing)					
	Storage	10%RH to 90%RH (non-condensing)					
Recommended Ambience	Indoor (no direct sunlight); No corrosive gas, inflammable gas, oil mist or dust.						

① Measurement is taken at ambient temperature 25°C. Value depends on the thermal environment.

② Resistance is measured by DC current with standard 0.5 m cable.

③ Inductance is measured by current frequency of 1 kHz.

The contents of datasheet are subject to change without prior notice.

Dimension

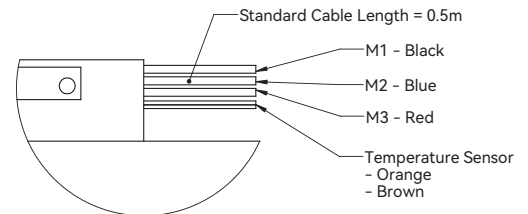
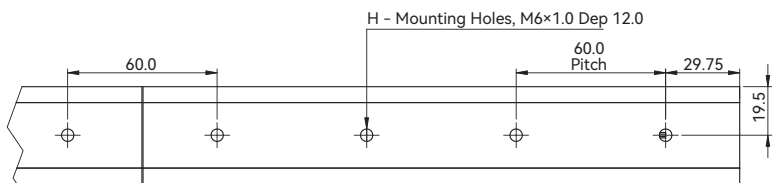
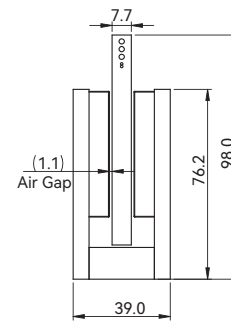
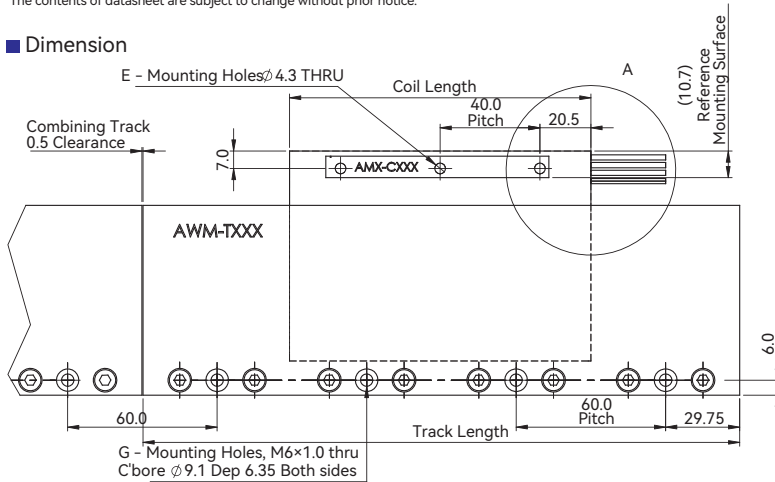

DETAIL A
SCALE 1 : 1

Motor Coil		
Model No	Coil Length	E
AWM4-S1	121.0	3
AWM4-S2	241.0	6
AWM4-S3	361.0	9

Motor Track			
Model No	Track Length	G	H
AWM4-TL180	179.5	3	3
AWM4-TL240	239.5	4	4
AWM4-TL300	299.5	5	5
AWM4-TL600	599.5	10	10

Force-Speed Curve

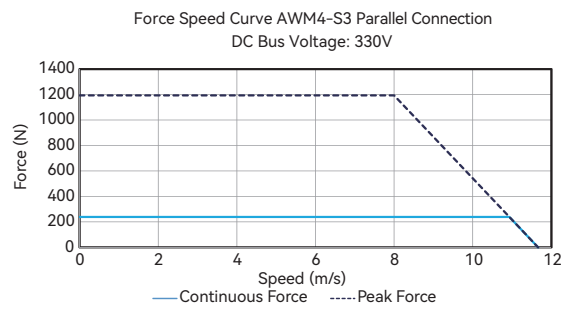
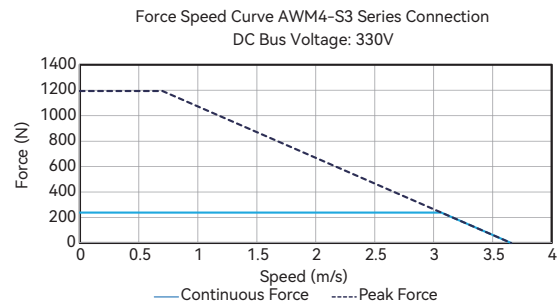
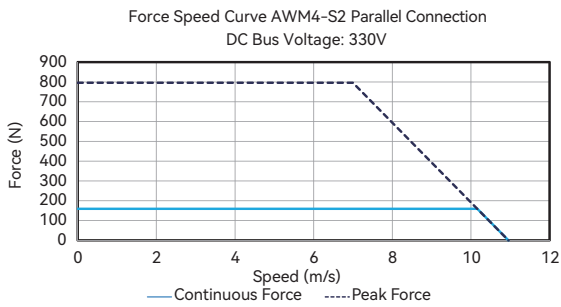
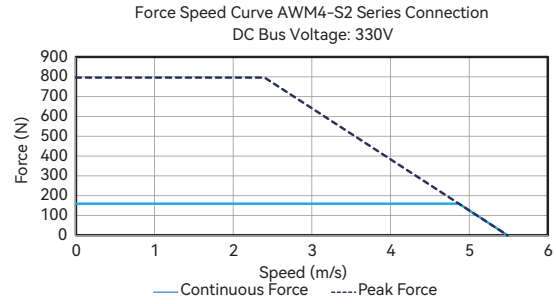
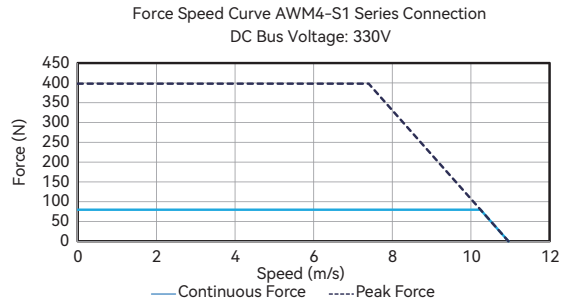

Part Numbering

Motor Coil

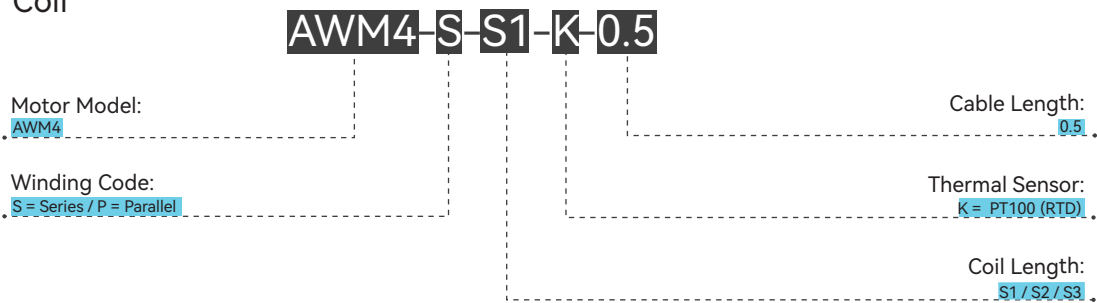

Motor Track

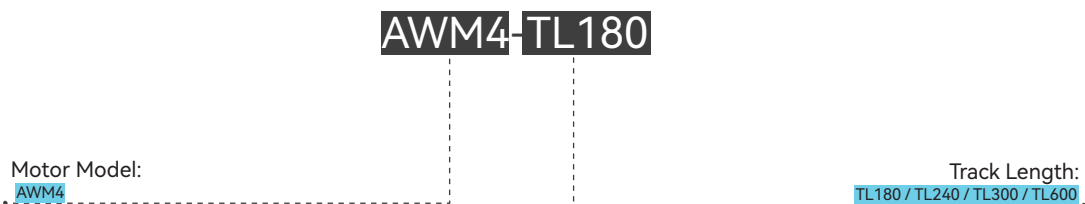

AWM5

			AWM5-S1	AWM5-S2		AWM5-S3	
Performance Parameters	Symbol	Unit	Series	Series	Parallel	Series	Parallel
Continuous Force (NC) @100°C ①	F_{cn}	N	138.3	276.5	276.5	414.8	414.8
Peak Force	F_{pk}	N	691.3	1382.5	1382.5	2073.8	2073.8
Force Constant $\pm 10\%$	K_f	N/Arms	55.3	110.6	55.3	165.9	83.0
Back EMF Constant $\pm 10\%$	K_e	Vpeak/(m/s)	45.2	90.3	45.2	135.5	67.7
Motor Constant @25°C	K_m	N/Sqrt(W)	19.6	27.7	27.7	34.0	51.0
Resistance (L-L) 25°C $\pm 10\%$ ②	R_{25}	Ω	5.3	10.6	2.7	15.9	1.8
Inductance (L-L) $\pm 30\%$ ③	L	mH	11.1	22.3	5.6	33.4	3.7
Electrical Time Constant	τ_e	ms	2.1	2.1	2.1	2.1	2.1
Continuous Current (NC) @100°C ①	I_{cn}	Arms	2.5	2.5	5.0	2.5	5.0
Peak Current	I_{pk}	Arms	12.5	12.5	25.0	12.5	25.0
Continuous Power Dissipation (NC) @100°C ①	P_{cn}	W	64.0	128.1	128.1	192.1	85.4
Max. Coil Temperature	t_{max}	°C	125.0	125.0	125.0	125.0	125.0
Thermal Dissipation Constant (NC) ①	K_{thn}	W/°C	0.9	1.7	1.7	2.6	1.1
Max. Bus Voltage	U_{bus}	Vdc	330.0	330.0	330.0	330.0	330.0
Magnetic Period	T_{NN}	mm	84.0	84.0	84.0	84.0	84.0
Attraction Force	F_a	kN	0.0	0.0	0.0	0.0	0.0
Mechanical Parameters							
Coil Mass (NC)	m_{cn}	kg	0.88	1.76	1.76	2.64	2.64
Coil Length (NC)	L_{cn}	mm	169.0	337.0	337.0	505.0	505.0
Track Mass Per Meter	m_{track}	kg/m	25.08	25.08	25.08	25.08	25.08
Other Information							
Insulation Class	Class B (130°C)						
Protection Grade	IP00						
Compliance with Global Standards	RoHS, CE						
Ambient Temperature	Operation	0°C to 40°C (non-freezing)					
	Storage	-15°C to 70°C (non-freezing)					
Ambient Humidity	Operation	10%RH to 80%RH (non-condensing)					
	Storage	10%RH to 90%RH (non-condensing)					
Recommended Ambience	Indoor (no direct sunlight); No corrosive gas, inflammable gas, oil mist or dust.						

① Measurement is taken at ambient temperature 25°C. Value depends on the thermal environment.

② Resistance is measured by DC current with standard 0.5 m cable.

③ Inductance is measured by current frequency of 1 kHz.

The contents of datasheet are subject to change without prior notice.

Dimension

E - Mounting Holes $\phi 5.3$ THRU ALL

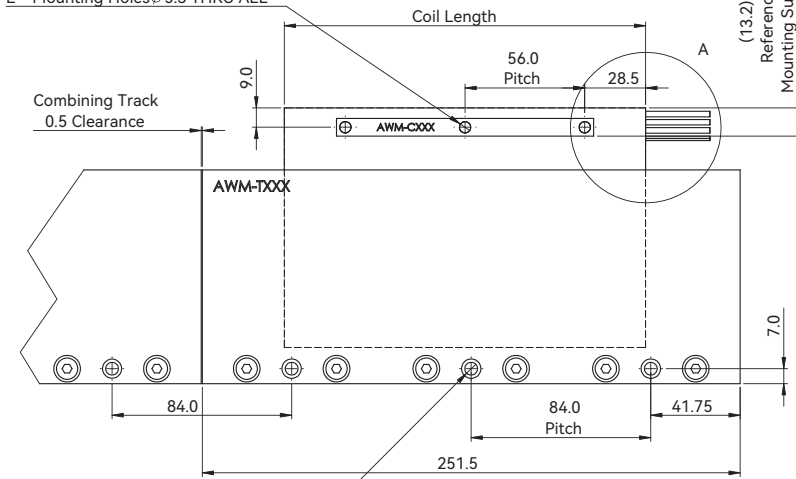

G - Mounting Holes, M6x1.0 thru C'bore $\phi 9.1$ Dep 9.0 Both sides

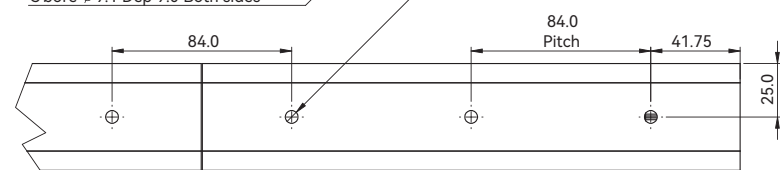

Motor Coil			Motor Track			
Model No	Coil Length	E	Model No	Track Length	G	H
AWM5-S1	169.0	3	AWM5-TL252	251.5	3	3
AWM5-S2	337.0	6	AWM5-TL420	419.5	5	5
AWM5-S3	505.0	9	AWM5-TL588	587.5	7	7

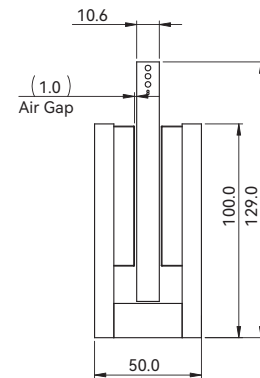

Standard Cable Length = 0.5m

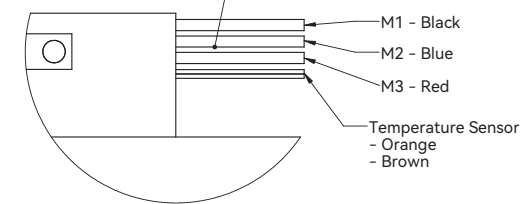

DETAIL A
SCALE 4 : 3.5

Force-Speed Curve

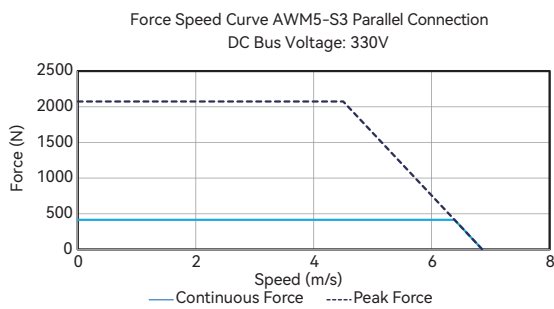
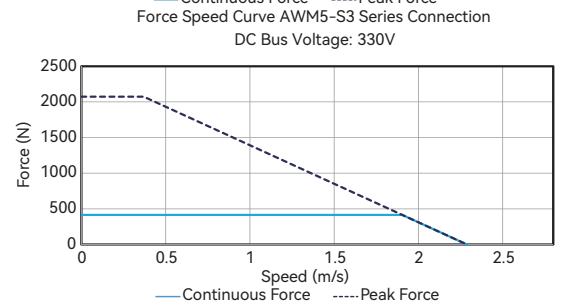
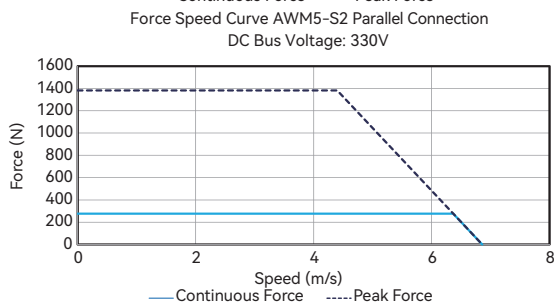
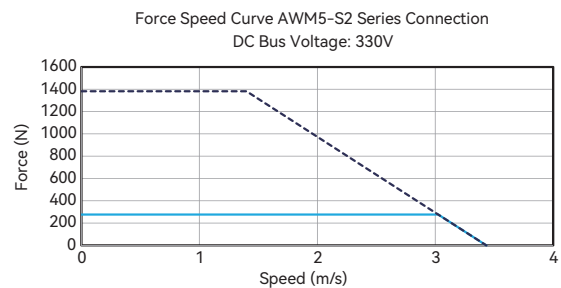
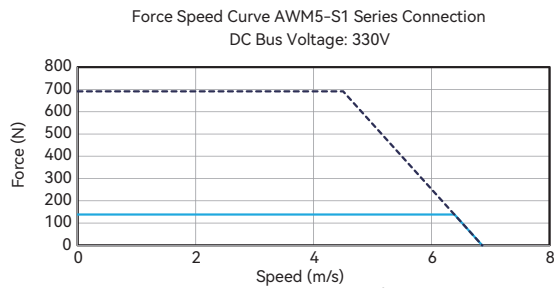

Part Numbering

Motor Coil

AWM5-S-S1-K-0.5

Motor Model:

AWM5

Winding Code:

S = Series / P = Parallel

Cable Length:

0.5

Thermal Sensor:

K = PT100 (RTD)

Coil Length:

S1 / S2 / S3

Motor Track

AWM5-TL252

Motor Model:

AWM5

Track Length:

TL252 / TL420 / TL588

AWM6

			AWM6-S1	AWM6-S2		AWM6-S3
Performance Parameters	Symbol	Unit	Series	Series	Parallel	Parallel
Continuous Force (NC) @100°C ^①	F _{cn}	N	256.4	512.7	512.7	769.1
Peak Force	F _{pk}	N	1281.8	2563.5	2563.5	3845.3
Force Constant ±10%	K _f	N/Arms	106.8	213.63	106.8	160.2
Back EMF Constant ±10%	K _e	Vpeak/(m/s)	87.2	174.4	87.2	130.8
Motor Constant @25°C	K _m	N/Sqrt(W)	28.8	40.7	40.7	74.7
Resistance (L-L) 25°C ±10% ^②	R ₂₅	Ω	9.2	18.4	4.6	3.1
Inductance (L-L) ±30% ^③	L	mH	23.0	46.0	11.5	7.7
Electrical Time Constant	τ _e	ms	2.5	2.5	2.5	2.5
Continuous Current (NC) @100°C ^①	I _{cn}	Arms	2.4	2.4	4.8	4.8
Peak Current	I _{pk}	Arms	12.0	12.0	24.0	24.0
Continuous Power Dissipation (NC) @100°C ^①	P _{cn}	W	102.4	204.9	204.9	136.6
Max. Coil Temperature	t _{max}	°C	125.0	125.0	125.0	125.0
Thermal Dissipation Constant (NC) ^①	K _{thn}	W/°C	1.4	2.7	2.7	1.8
Max. Bus Voltage	U _{bus}	Vdc	330.0	330.0	330.0	330.0
Magnetic Period	τ _{NN}	mm	84.0	84.0	84.0	84.0
Attraction Force	F _a	kN	0.0	0.0	0.0	0.0
Mechanical Parameters						
Coil Mass (NC)	m _{cn}	kg	1.8	3.7	3.7	5.5
Coil Length (NC)	L _{cn}	mm	169.0	337.0	337.0	505.0
Track Mass Per Meter	m _{track}	kg/m	66.7	66.7	66.7	66.7
Other Information						
Insulation Class	Class B (130°C)					
Protection Grade	IP00					
Compliance with Global Standards	RoHS, CE					
Ambient Temperature	Operation	0°C to 40°C (non-freezing)				
	Storage	-15°C to 70°C (non-freezing)				
Ambient Humidity	Operation	10%RH to 80%RH (non-condensing)				
	Storage	10%RH to 90%RH (non-condensing)				
Recommended Ambience	Indoor (no direct sunlight); No corrosive gas, inflammable gas, oil mist or dust.					

① Measurement is taken at ambient temperature 25°C. Value depends on the thermal environment.

② Resistance is measured by DC current with standard 0.5 m cable.

③ Inductance is measured by current frequency of 1 kHz.

The contents of datasheet are subject to change without prior notice.

Dimension

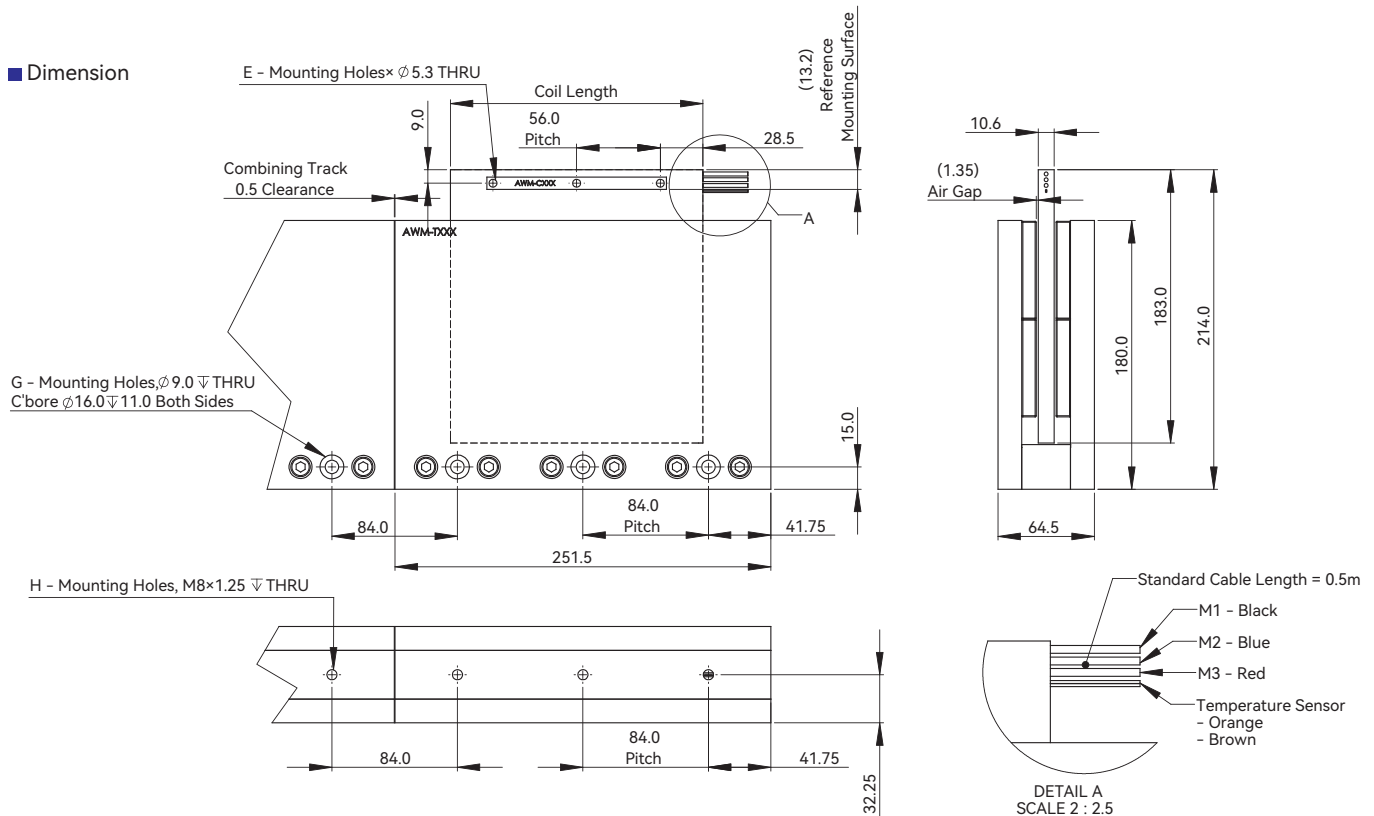

Motor Coil		
Model No	Coil Length	E
AWM6-S1	169.0	3
AWM6-S2	337.0	6
AWM6-S3	505.0	9

Motor Track			
Model No	Track Length	G	H
AWM6-TL252	251.5	3	3
AWM6-TL420	419.5	5	5
AWM6-TL588	587.5	7	7

Force-Speed Curve

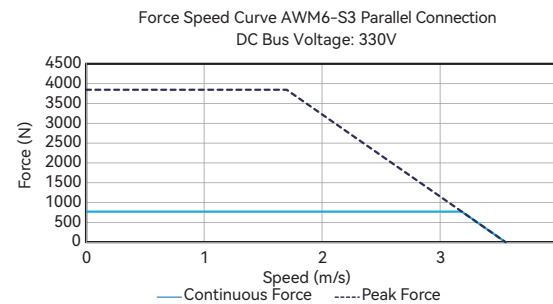
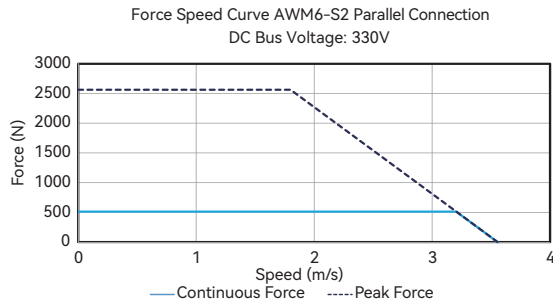
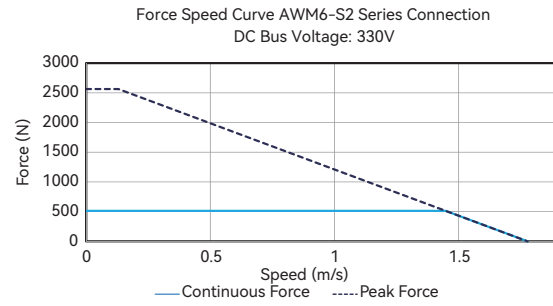
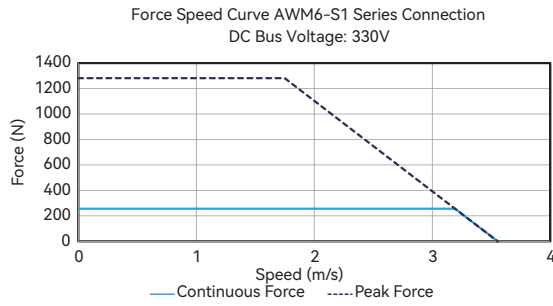

Part Numbering

Motor Coil



Motor Track

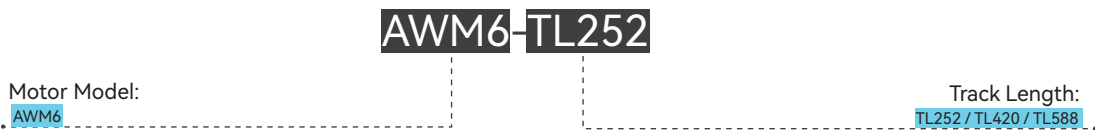

Motor Cable Connection

