

AQM SERIES

- ▶ Ironcore technology
- ▶ Low cogging force
- ▶ Higher cost performance
- ▶ High response and flexibility
- ▶ High force and stiffness

EN-26.3.1

Introduction >>>

Iron Core AQM series linear motors have a low cogging force, a competitive cost advantage, exceptionally narrow width for dimensionally constrained applications and are ideal for long travel strokes.

Continuous Force $F_{cn} = 20.3N \sim 506N$

Peak Force $F_{pk} = 49.7N \sim 1243N$

Features >>>

- ▶ Iron core technology and low cogging force
- ▶ Higher cost performance
- ▶ Multiple coil lengths to select

Applications >

Applicable to point-to-point micron meter level positioning; unlimited travel stroke with top speed of 5m/s or faster (stroke of 100m or longer).

Applications & Industries: high speed positioning systems for product handling in semiconductor, photovoltaic and lithium battery, glass and LCD applications, as well as industrial printing machines, laser processing machines with demanding precision and motion control requirements.

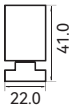
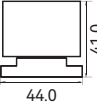
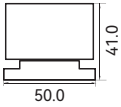
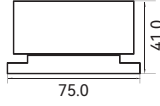
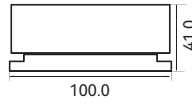
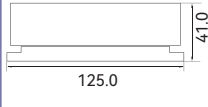
	Series	Coil Length (mm)	● Continuous Force (F_{cn}) / ■ PeakForce (F_{pk})					Unit: N	
			50	100	200	300	400	500
	AQM8-B1	133	● 20.3 / ■ 49.7						
	AQM24-B1	133		● 60.8 / ■ 149.2					
	AQM30-B1	133		● 75.9 / ■ 186.4					
	AQM30-B2	268			● 151.9 / ■ 372.9				
	AQM50-B1	133			● 126.6 / ■ 310.7				
	AQM50-B2	268				● 253.1 / ■ 621.5			
	AQM80-B1	133				● 202.5 / ■ 497.2			
	AQM80-B2	268					● 405 / ■ 994.4		
	AQM100-B1	133					● 253.1 / ■ 621.5		
	AQM100-B2	268						● 506 / ■ 1243	

AQM8-B1

			AQM8-B1
Performance Parameters	Symbol	Unit	Series
Continuous Force (NC) @100°C ❶	F_{cn}	N	20.3
Peak Force	F_{pk}	N	49.7
Force Constant $\pm 10\%$	K_f	N/Arms	8.1
Back EMF Constant $\pm 10\%$	K_e	Vpeak/(m/s)	6.6
Motor Constant @25°C	K_m	N/Sqrt(W)	3.8
Resistance (L-L) 25°C $\pm 10\%$ ❷	R_{25}	Ω	3.1
Inductance (L-L) $\pm 30\%$ ❸	L	mH	22.7
Electrical Time Constant	τ_e	ms	7.3
Continuous Current (NC) @100°C ❶	I_{cn}	Arms	2.5
Peak Current	I_{pk}	Arms	9.0
Continuous Power Dissipation (NC) @100°C ❶	P_{cn}	W	37.5
Max. Coil Temperature	t_{max}	°C	100
Thermal Dissipation Constant (NC) ❶	K_{thn}	W/°C	0.5
Max. Bus Voltage	U_{bus}	Vdc	600
Magnetic Period	T_{NN}	mm	30
Attraction Force	F_a	N	75
Mechanical Parameters			
Coil Mass (NC)	m_{cn}	kg	0.4
Coil Length (NC)	L_{cn}	mm	133
Track Mass Per Meter	m_{track}	kg/m	1.3
Other Information			
Insulation Class	Class B (130°C)		
Protection Grade	IP00		
Compliance with Global Standards	RoHS, CE, UL(option)		
Ambient Temperature	Operation	0°C to 40°C (non-freezing)	
	Storage	-15°C to 70°C (non-freezing)	
Ambient Humidity	Operation	10%RH to 80%RH (non-condensing)	
	Storage	10%RH to 90%RH (non-condensing)	
Recommended Ambience	Indoor (no direct sunlight); No corrosive gas, inflammable gas, oil mist or dust.		

❶ Measurement is taken at ambient temperature 25°C. Value depends on the thermal environment.
Abbreviations: NC-Natural Cooling.

❷ Resistance is measured by DC current with standard 0.5 m cable.

❸ Inductance is measured by current frequency of 1 kHz.

The contents of datasheet are subject to change without prior notice.

Dimension

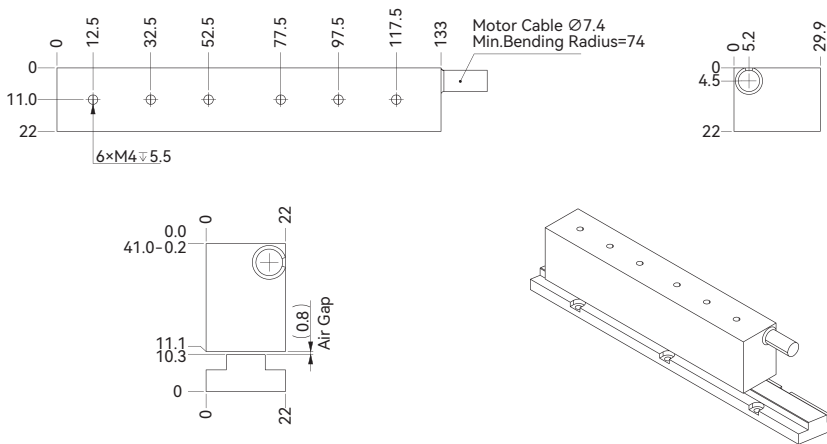

Force-Speed Curve

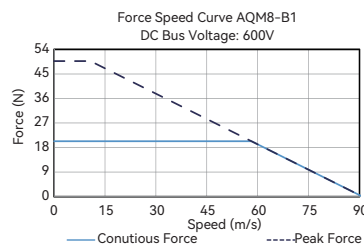
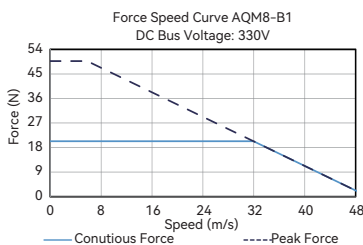

AQM8 Track

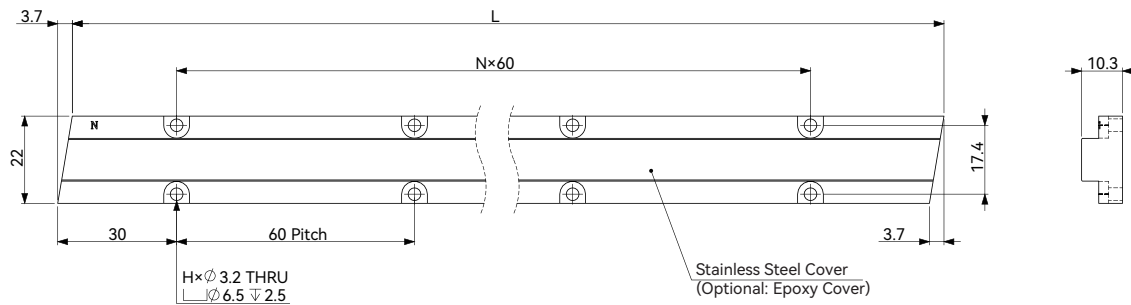

Magnet Track	L	N	H
AQM8-TL180-S	180	2	6
AQM8-TL300-S	300	4	10
AQM8-TL420-S	420	6	14

For epoxy cover option, change "-S" to "-E". (e.g. AQM8-TL180-E)

AQM24-B1

			AQM24-B1
Performance Parameters	Symbol	Unit	Parallel
Continuous Force (NC) @100°C ❶	F_{cn}	N	60.8
Peak Force	F_{pk}	N	149.2
Force Constant ±10%	K_f	N/Arms	24.3
Back EMF Constant ±10%	K_e	Vpeak/(m/s)	19.8
Motor Constant @25°C	K_m	N/Sqrt(W)	8.8
Resistance (L-L) 25°C ±10% ❷	R_{25}	Ω	5.1
Inductance (L-L) ±30% ❸	L	mH	39.1
Electrical Time Constant	τ_e	ms	7.7
Continuous Current (NC) @100°C ❶	I_{cn}	Arms	2.5
Peak Current	I_{pk}	Arms	9.0
Continuous Power Dissipation (NC) @100°C ❶	P_{cn}	W	61.6
Max. Coil Temperature	t_{max}	°C	100
Thermal Dissipation Constant (NC) ❶	K_{thn}	W/°C	0.8
Max. Bus Voltage	U_{bus}	Vdc	600
Magnetic Period	T_{MN}	mm	30
Attraction Force	F_a	N	224
<hr/>			
Coil Mass (NC)	m_{cn}	kg	0.8
Coil Length (NC)	L_{cn}	mm	133
Track Mass Per Meter	m_{track}	kg/m	2.7
<hr/>			
Insulation Class	Class B (130°C)		
Protection Grade	IP00		
Compliance with Global Standards	RoHS, CE, UL(option)		
Ambient Temperature	Operation	0°C to 40°C (non-freezing)	
	Storage	-15°C to 70°C (non-freezing)	
Ambient Humidity	Operation	10%RH to 80%RH (non-condensing)	
	Storage	10%RH to 90%RH (non-condensing)	
Recommended Ambience	Indoor (no direct sunlight); No corrosive gas, inflammable gas, oil mist or dust.		

❶ Measurement is taken at ambient temperature 25°C. Value depends on the thermal environment.
Abbreviations:NC-Natural Cooling.

❷ Resistance is measured by DC current with standard 0.5 m cable.

❸ Inductance is measured by current frequency of 1 kHz.

The contents of datasheet are subject to change without prior notice.

Dimension

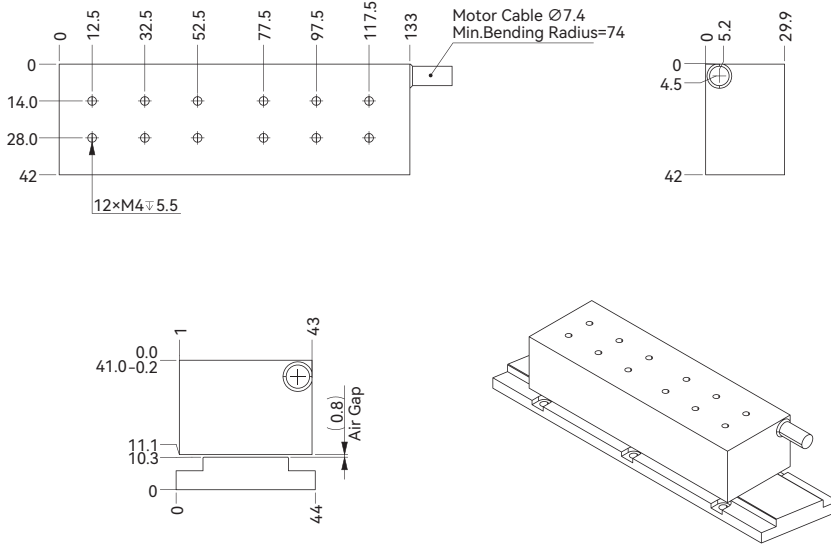

Force-Speed Curve

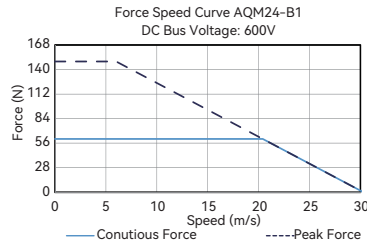
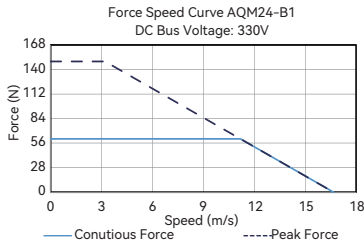

AQM24 Track

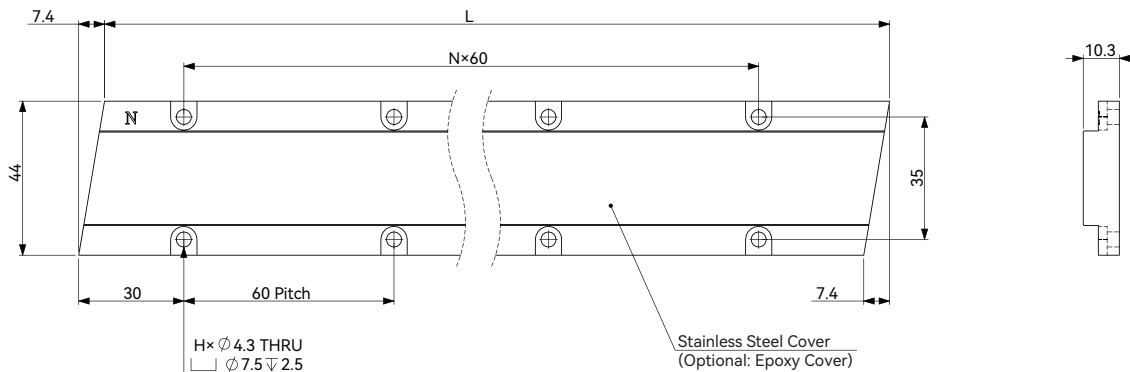

Magnet Track	L	N	H
AQM24-TL180-S	180	2	6
AQM24-TL300-S	300	4	10
AQM24-TL420-S	420	6	14

For epoxy cover option, change "S" to "E". (e.g. AQM24-TL180-E)

AQM30

			AQM30-B1	AQM30-B2
Performance Parameters	Symbol	Unit	Series	Parallel
Continuous Force (NC) @100°C ^①	F _{cn}	N	75.9	151.9
Peak Force	F _{pk}	N	186.4	372.9
Force Constant ±10%	K _f	N/Arms	30.4	30.4
Back EMF Constant ±10%	K _e	Vpeak/(m/s)	24.8	24.8
Motor Constant @25°C	K _m	N/Sqrt(W)	10.3	14.6
Resistance (L-L) 25°C ±10% ^②	R ₂₅	Ω	5.8	2.9
Inductance (L-L) ±30% ^③	L	mH	47.1	23.6
Electrical Time Constant	T _e	ms	8.2	8.2
Continuous Current (NC) @100°C ^①	I _{cn}	Arms	2.5	5.0
Peak Current	I _{pk}	Arms	9.0	18.0
Continuous Power Dissipation (NC) @100°C ^①	P _{cn}	W	69.6	139.2
Max. Coil Temperature	t _{max}	°C	100	100
Thermal Dissipation Constant (NC) ^①	K _{thn}	W/°C	0.9	1.9
Max. Bus Voltage	U _{bus}	Vdc	600	600
Magnetic Period	T _{NN}	mm	30	30
Attraction Force	F _a	N	280	560
Mechanical Parameters				
Coil Mass (NC)	m _{cn}	kg	1.0	1.9
Coil Length (NC)	L _{cn}	mm	133	268
Track Mass Per Meter	m _{track}	kg/m	3.0	3.0
Other Information				
Insulation Class	Class B (130°C)			
Protection Grade	IP00			
Compliance with Global Standards	RoHS, CE, UL(option)			
Ambient Temperature	Operation	0°C to 40°C (non-freezing)		
	Storage	-15°C to 70°C (non-freezing)		
Ambient Humidity	Operation	10%RH to 80%RH (non-condensing)		
	Storage	10%RH to 90%RH (non-condensing)		
Recommended Ambience	Indoor (no direct sunlight); No corrosive gas, inflammable gas, oil mist or dust.			

^① Measurement is taken at ambient temperature 25°C. Value depends on the thermal environment.
Abbreviations: NC-Natural Cooling.

^② Resistance is measured by DC current with standard 0.5 m cable.

^③ Inductance is measured by current frequency of 1 kHz.

The contents of datasheet are subject to change without prior notice.

Dimension

AQM30-B1

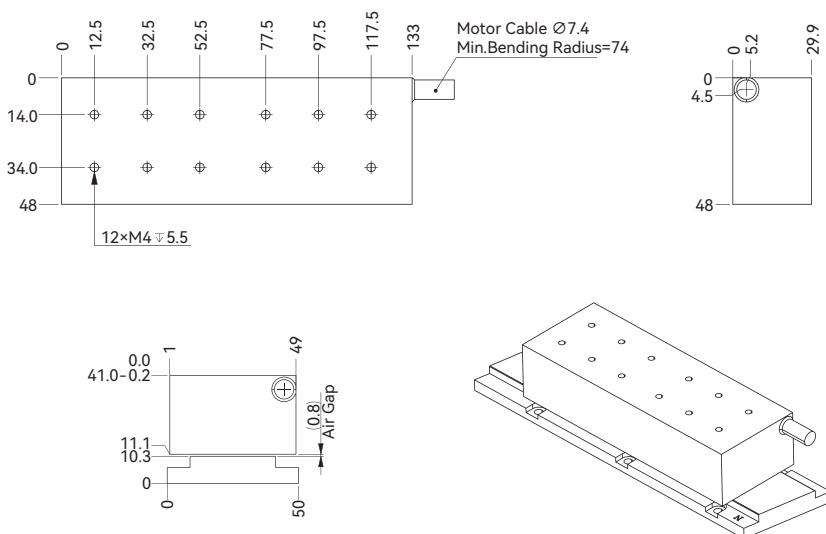

AQM30-B2

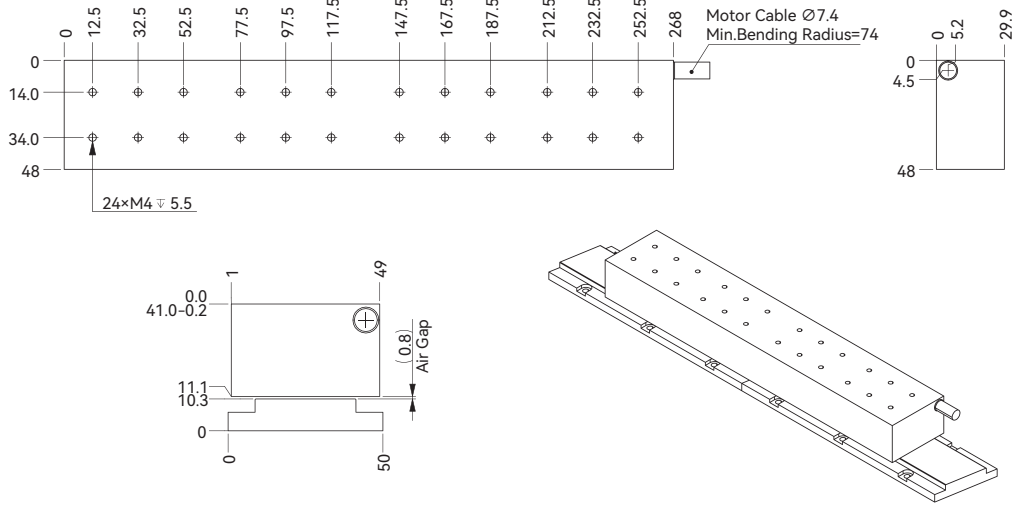

Force-Speed Curve

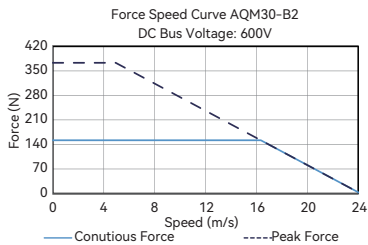
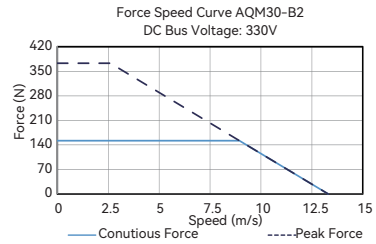
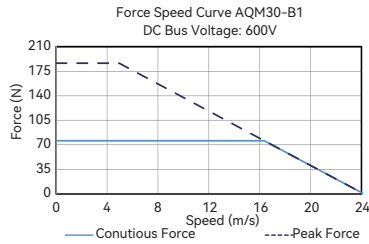
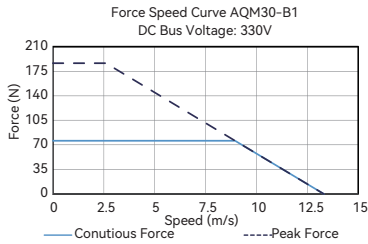

AQM30 Track

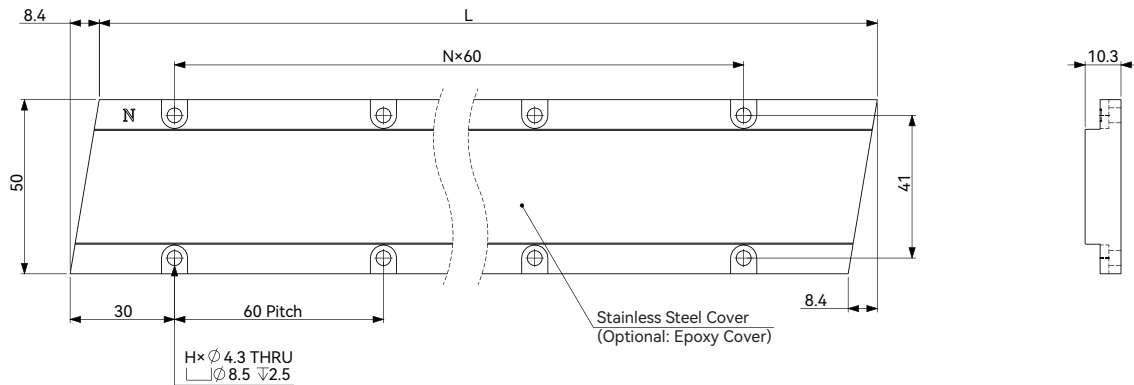

Magnet Track	L	N	H
AQM30-TL180-S	180	2	6
AQM30-TL300-S	300	4	10
AQM30-TL420-S	420	6	14

For epoxy cover option, change "-S" to "-E". (e.g. AQM30-TL180-E)

AQM80

			AQM80-B1	AQM80-B2
Performance Parameters	Symbol	Unit	Series	Parallel
Continuous Force (NC) @100°C	F_{cn}	N	202.5	405.0
Peak Force	F_{pk}	N	497.2	994.4
Force Constant $\pm 10\%$	K_f	N/Arms	81.0	81.0
Back EMF Constant $\pm 10\%$	K_e	V _{peak} /(m/s)	66.1	66.1
Motor Constant @25°C	K_m	N/Sqrt(W)	19.5	27.6
Resistance (L-L) 25°C $\pm 10\%$	R_{25}	Ω	11.5	5.8
Inductance (L-L) $\pm 30\%$	L	mH	100.0	50.0
Electrical Time Constant	τ_e	ms	8.7	8.7
Continuous Current (NC) @100°C	I_{cn}	Arms	2.5	5.0
Peak Current	I_{pk}	Arms	9.0	18.0
Continuous Power Dissipation (NC) @100°C	P_{cn}	W	138.9	277.9
Max. Coil Temperature	t_{max}	°C	100	100
Thermal Dissipation Constant (NC)	K_{thn}	W/°C	1.9	3.7
Max. Bus Voltage	U_{bus}	V _{dc}	600	600
Magnetic Period	T_{NN}	mm	30	30
Attraction Force	F_a	N	747	1494
Mechanical Parameters				
Coil Mass (NC)	m_{cn}	kg	1.9	3.9
Coil Length (NC)	L_{cn}	mm	133	268
Track Mass Per Meter	m_{track}	kg/m	6.1	6.1
Other Information				
Insulation Class	Class B (130°C)			
Protection Grade	IP00			
Compliance with Global Standards	RoHS, CE, UL(option)			
Ambient Temperature	Operation	0°C to 40°C (non-freezing)		
	Storage	-15°C to 70°C (non-freezing)		
Ambient Humidity	Operation	10%RH to 80%RH (non-condensing)		
	Storage	10%RH to 90%RH (non-condensing)		
Recommended Ambience	Indoor (no direct sunlight); No corrosive gas, inflammable gas, oil mist or dust.			

● Measurement is taken at ambient temperature 25°C. Value depends on the thermal environment.

Abbreviations: NC-Natural Cooling.

● Resistance is measured by DC current with standard 0.5 m cable.

● Inductance is measured by current frequency of 1 kHz.

The contents of datasheet are subject to change without prior notice.

Dimension

AQM80-B1

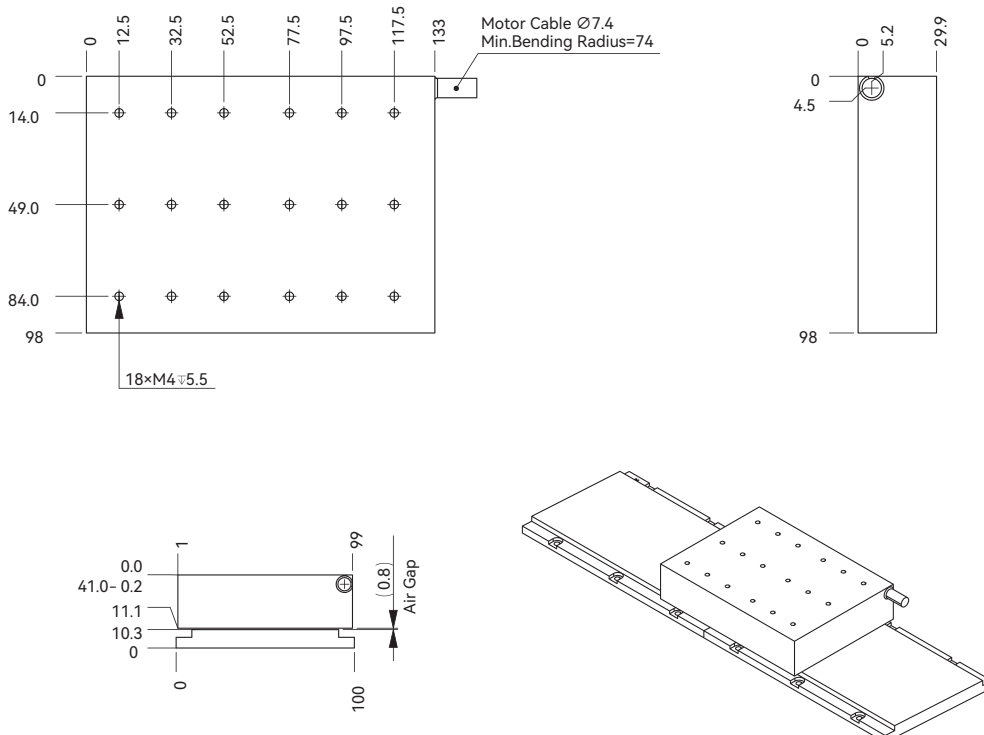

AQM80-B2

Introduction
Sizing Guide
Frequently Asked Questions

Linear Motors

Voice Coil Motors

Direct Drive Rotary Motors

Magnet Spring

Motion Control of Gantry Stages

Akribis systems

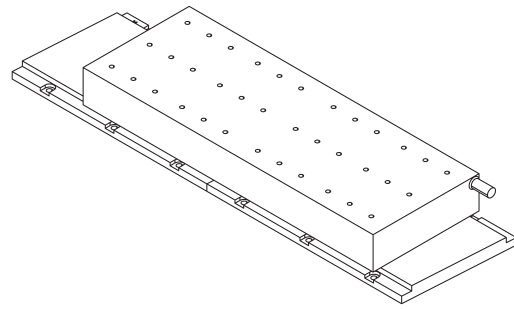
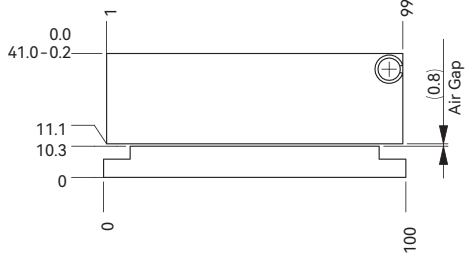
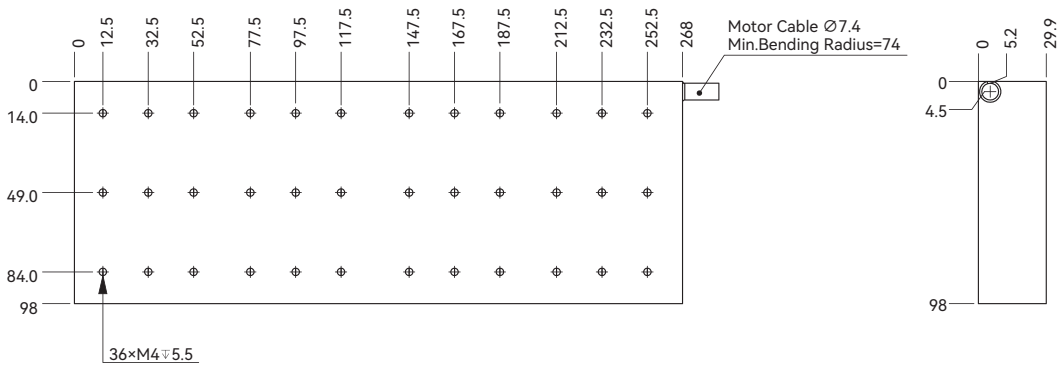

Force-Speed Curve

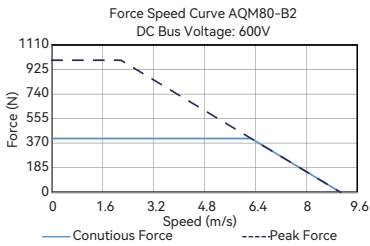
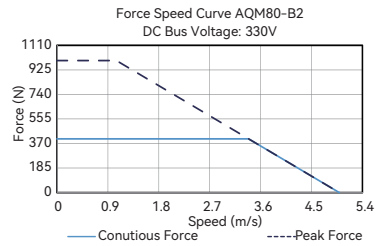
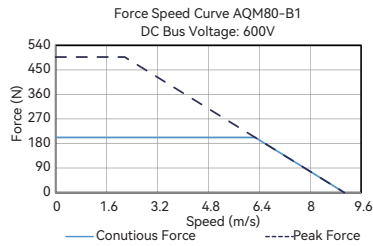
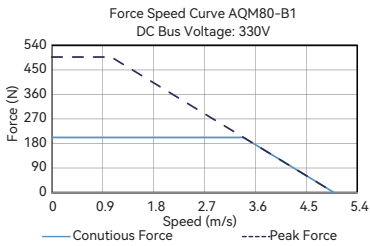

AQM80 Track

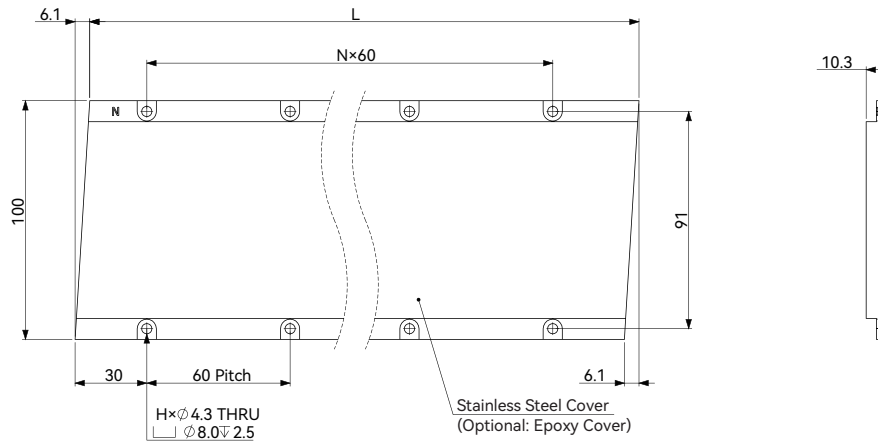

Magnet Track	L	N	H
AQM80-TL180-S	180.0	2	6
AQM80-TL300-S	300.0	4	10
AQM80-TL420-S	420.0	6	14

For epoxy cover option, change "-S" to "-E". (e.g. AQM80-TL180-E)

AQM100

			AQM100-B1	AQM100-B2
Performance Parameters	Symbol	Unit	Series	Parallel
Continuous Force (NC) @100°C ①	F_{cn}	N	253.1	506
Peak Force	F_{pk}	N	621.5	1243
Force Constant ±10%	K_f	N/Arms	101.3	101.3
Back EMF Constant ±10%	K_e	Vpeak/(m/s)	82.7	82.7
Motor Constant @25°C	K_m	N/Sqrt(W)	21.8	30.8
Resistance (L-L) 25°C ±10% ②	R_{25}	Ω	14.4	7.2
Inductance (L-L) ±30% ③	L	mH	125.0	62.5
Electrical Time Constant	τ_e	ms	8.7	8.7
Continuous Current (NC) @100°C ①	I_{cn}	Arms	2.5	5.0
Peak Current	I_{pk}	Arms	9.0	18.0
Continuous Power Dissipation (NC) @100°C ①	P_{cn}	W	173.7	347.4
Max. Coil Temperature	t_{max}	°C	100	100
Thermal Dissipation Constant (NC) ①	K_{thn}	W/°C	2.3	4.6
Max. Bus Voltage	U_{bus}	Vdc	600	600
Magnetic Period	T_{NN}	mm	30	30
Attraction Force	F_a	N	934	1868
Mechanical Parameters				
Coil Mass (NC)	m_{cn}	kg	2.3	4.7
Coil Length (NC)	L_{cn}	mm	133	268
Track Mass Per Meter	m_{track}	kg/m	7.7	7.7
Other Information				
Insulation Class	Class B (130°C)			
Protection Grade	IP00			
Compliance with Global Standards	RoHS, CE, UL(option)			
Ambient Temperature	Operation	0°C to 40°C (non-freezing)		
	Storage	-15°C to 70°C (non-freezing)		
Ambient Humidity	Operation	10%RH to 80%RH (non-condensing)		
	Storage	10%RH to 90%RH (non-condensing)		
Recommended Ambience	Indoor (no direct sunlight); No corrosive gas, inflammable gas, oil mist or dust.			

① Measurement is taken at ambient temperature 25°C. Value depends on the thermal environment.
Abbreviations: NC-Natural Cooling.

② Resistance is measured by DC current with standard 0.5 m cable.

③ Inductance is measured by current frequency of 1 kHz.

The contents of datasheet are subject to change without prior notice.

AQM Series

Dimension

AQM100-B1

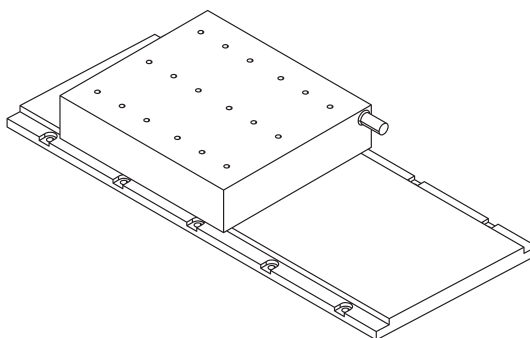
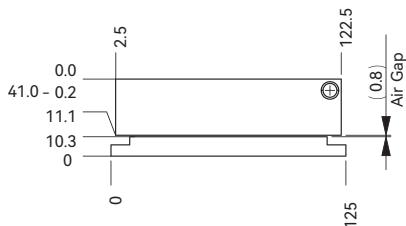
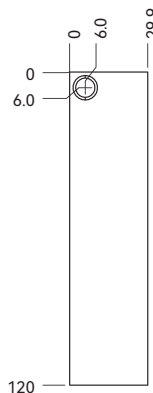
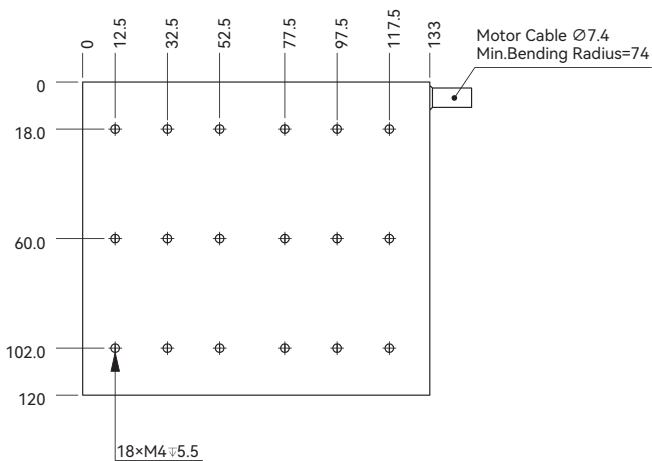

AQM100-B2

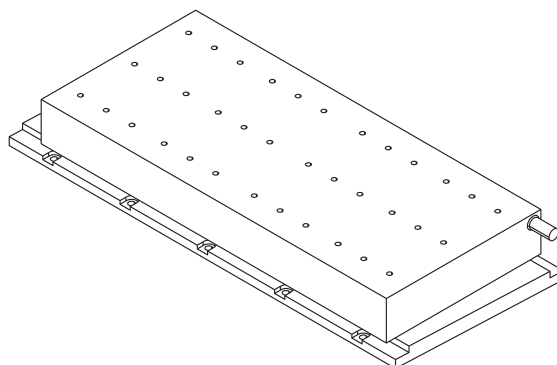
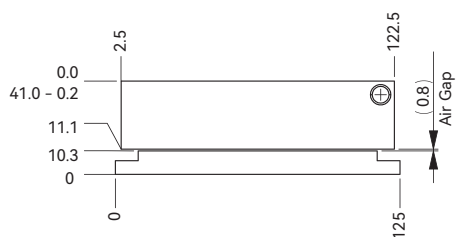
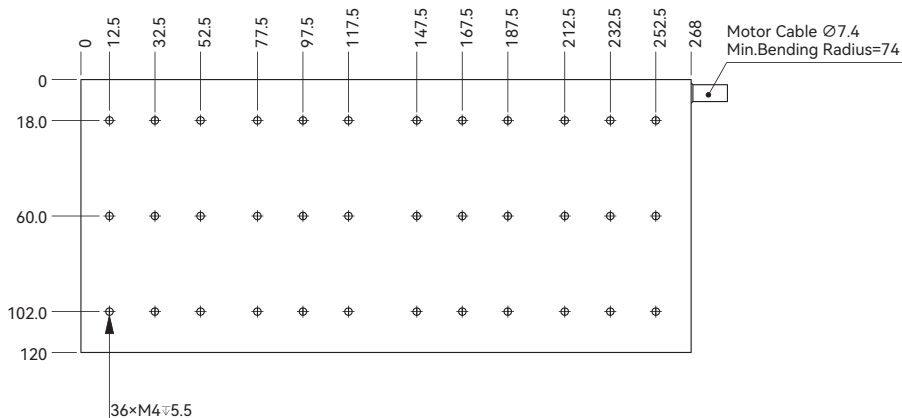

Force-Speed Curve

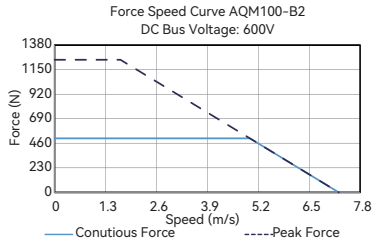
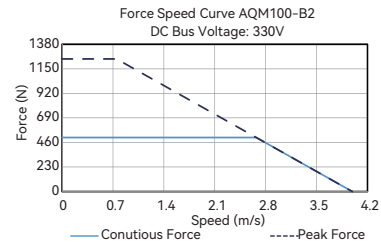
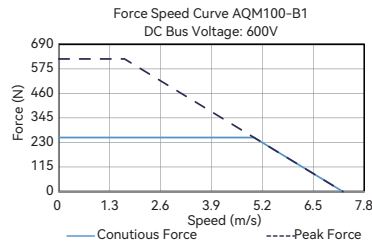
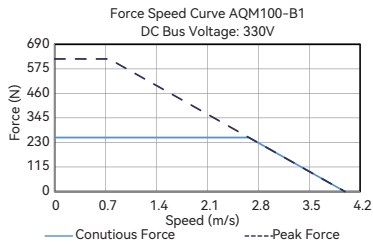

AQM100 Track

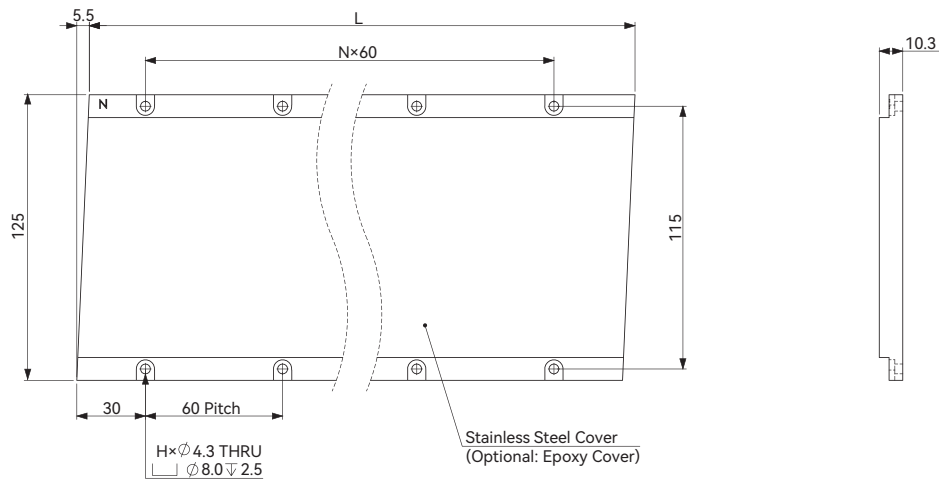

Magnet Track	L	N	H
AQM100-TL180-S	180	2	6
AQM100-TL300-S	300	4	10
AQM100-TL420-S	420	6	14

For epoxy cover option, change "-S" to "-E". (e.g. AQM100-TL180-E)

Motor Cable Connection

Introduction
 Sizing Guide
 Frequently Asked Questions
 Linear Motors
 Voice Coil Motors
 Direct Drive Rotary Motors
 Magnet Spring
 Motion Control of Gantry Stages

PIN	DESCRIPTION	COLOR
-	M1	BROWN
-	M2	WHITE
-	M3	GREY
-	PE	YELLOW/GREEN
-	T1	PINK
-	T2	BLUE

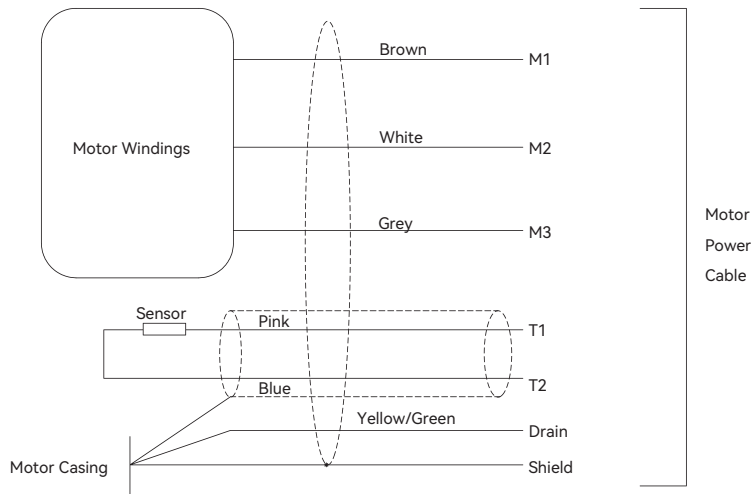
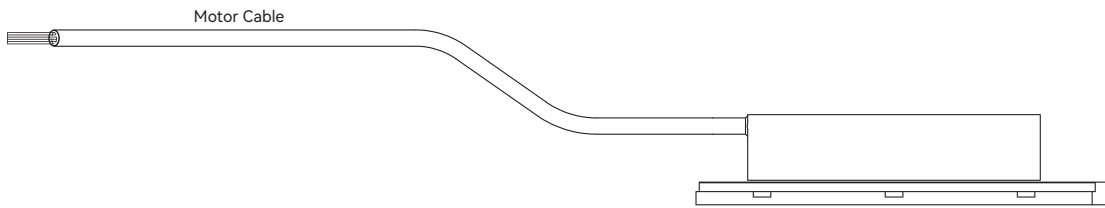
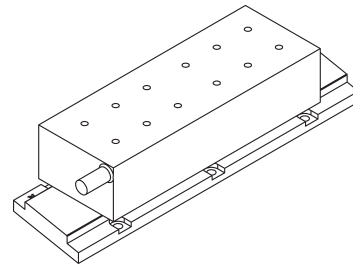

Part Numbering

Motor Coil

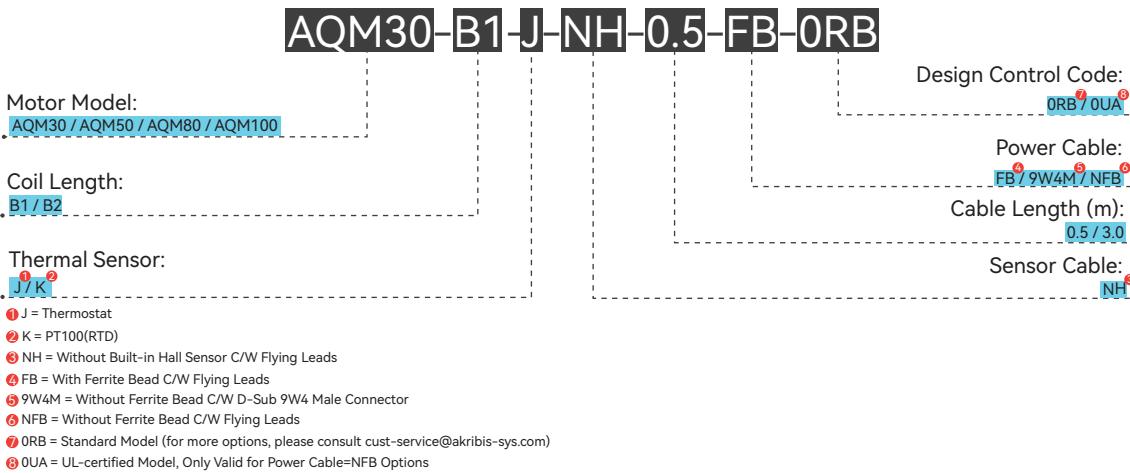
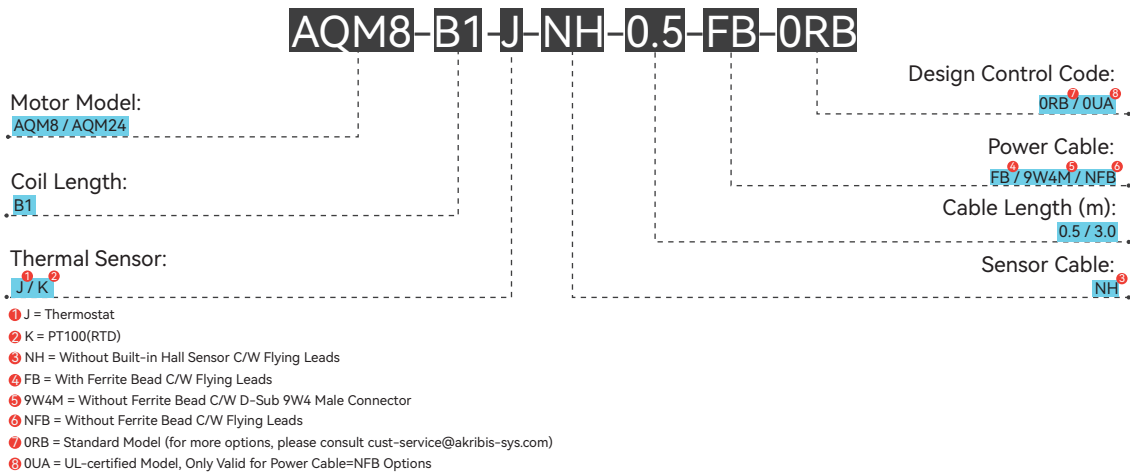

Motor Track

