



# APC SERIES

- ▶ Z-axis 2G acceleration
- ▶ 30mm stroke and 2-axis option
- ▶ Compact 2-axis design at only 16mm thickness
- ▶ Vacuum tip
- ▶ High force to weight ratio

EN-26.3.1

## APC16B-ZT30

Motor Specifications	Z-axis	T-axis
Motor	ALM015-T-B1	TP12
Continuous Force (NC) @100°C [Z-axis] <sup>1</sup>	10 N	7.40E-03 Nm
Continuous Torque (NC) @100°C [T-axis] <sup>1</sup>		
Peak Force [Z-axis]	36 N	1.85E-02 Nm
Peak Torque [T-axis]		
Force Constant ±10% [Z-axis]	8.1 N/Arms	9.25E-03 Nm/Arms
Torque Constant ±10% [T-axis]		
Back EMF Constant ±10%	6.6 Vpeak/(m/s)	7.91E-04 Vpeak/rpm
Resistance (L-L) @25°C ±10% [Z-axis   T-axis]	4.51 Ω	2.63 Ω
Inductance (L-L) ±30% [Z-axis] <sup>2</sup>	0.58 mH	0.23 mH
Inductance (L-L) ±20% [T-axis] <sup>2</sup>		
Continuous Current (NC) @100°C <sup>3</sup>	1.23 Arms	0.80 Arms
Peak Current	4.4 Arms	2.00 Arms
Max. Bus Voltage [Z-axis   T-axis]	60 Vdc	48 Vdc
Magnetic Period	16.5 mm	-
Attraction Force	-	4
Mechanical Specifications	Z-axis	T-axis
Effective Stroke	30 mm	360° (Limitless)
Resolution	0.5 μm	491520 counts/rev
Repeatability	±5 μm	±20 arcsec
Rated Payload	0.04 kg	
No-Load Moving Mass [Z-axis]	0.2 kg	7.68E-08 kg · m <sup>2</sup>
No-Load Rotor Inertia [T-axis]		
No-Load Total Mass	1 kg	
Max. Acceleration	20 m/s <sup>2</sup>	600 rad/s <sup>2</sup> <sup>4</sup>
Max. Velocity	0.5 m/s	60 rad/s <sup>4</sup>
Max. Pressure	0.8 MPa	
Suction Air Flow Requirement	≥ 8 L/min [ANR]	

<sup>1</sup> Measurement is taken at ambient temperature 25°C. Value depends on the thermal environment. <sup>2</sup> Resistance is measured by DC current with standard 1.0m lead wire.  
<sup>2</sup> Resistance is measured by DC current with standard 0.5m lead wire. <sup>3</sup> Inductance is measured by current frequency of 1kHz.  
 The contents of datasheet are subject to change without prior notice. <sup>4</sup> Max value for 1 revolution.

## Dimensional Drawing

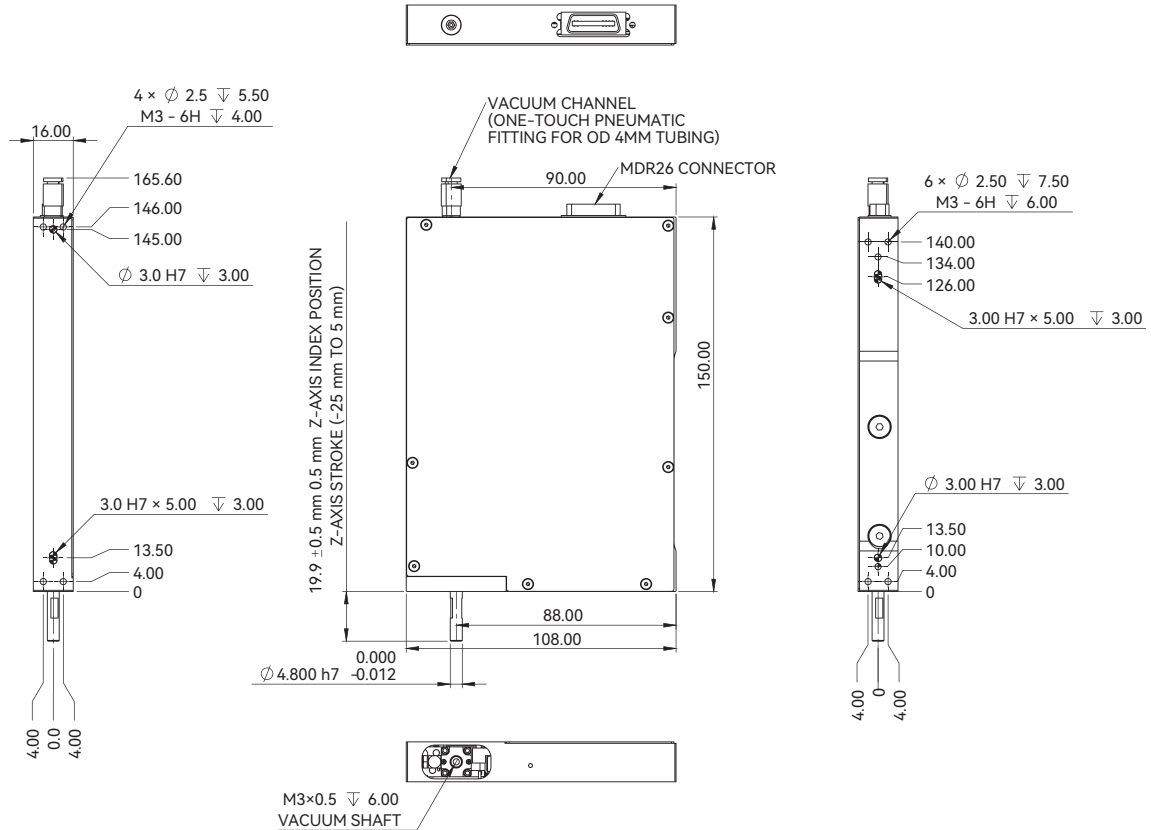

# APC16B-Z30

Motor Specifications	Z-axis
Motor	ALM015-T-B1
Continuous Force (NC) @100°C [Z-axis] <sup>①</sup>	10 N
Peak Force [Z-axis]	36 N
Force Constant ±10% [Z-axis]	8.1 N/Arms
Back EMF Constant ±10%	6.6 Vpeak/(m/s)
Resistance (L-L) @25°C ±10% [Z-axis] <sup>②</sup>	4.51 Ω
Inductance (L-L) ±30% [Z-axis] <sup>③</sup>	0.58 mH
Continuous Current (NC) @100°C <sup>①</sup>	1.23 Arms
Peak Current	4.4 Arms
Max. Bus Voltage [Z-axis]	60 Vdc
Magnetic Period	16.5 mm
Attraction Force	-
Mechanical Specifications	Z-axis
Effective Stroke	30 mm
Resolution	0.5 μm
Repeatability	±5 μm
Rated Payload	0.04 kg
No-Load Moving Mass [Z-axis]	0.2 kg
No-Load Total Mass	0.8 kg
Max. Acceleration	20 m/s <sup>2</sup>
Max. Velocity	0.5 m/s
Max. Pressure	0.8 MPa
Suction Air Flow Requirement	≥ 8 L/min [ANR]

① Measurement is taken at ambient temperature 25°C. Value depends on the thermal environment.  
 ② Resistance is measured by DC current with standard 0.5m lead wire.  
 ③ Inductance is measured by current frequency of 1kHz.  
 The contents of datasheet are subject to change without prior notice.

## Dimensional Drawing

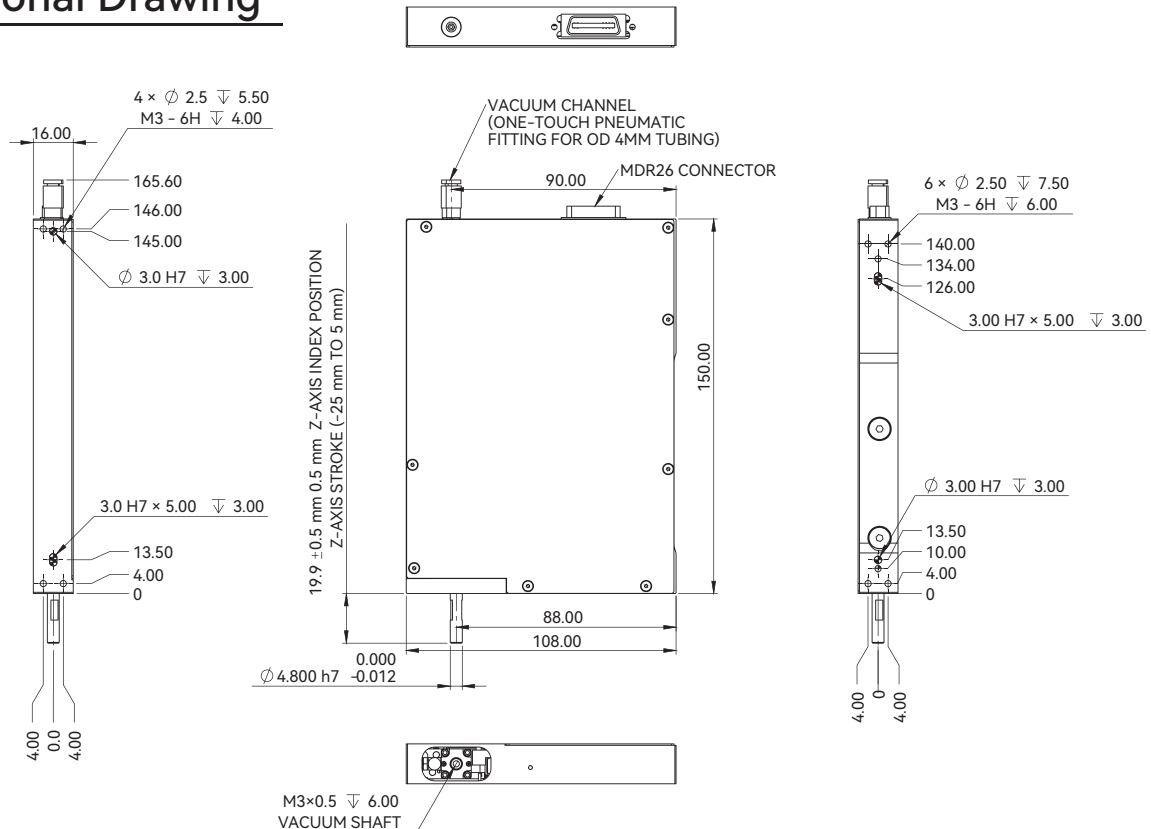

Introduction | Sizing Guide | Motion Control of Gantry Stages | Dual Guide Modules | Cross Roller Modules | Voice Coil Modules | Miniature Modules | Picker Modules | Air Bearing Modules | Stacked Stages | Gantry Stages | Wafer Stages

## Z-axis Motor

Performance Parameters	Unit	ALM015-T-B1
Continuous Force (NC) @100°C <sup>①</sup>	N	10.0
Stall Force (NC) @100°C <sup>① ②</sup>	N	8.3
Peak Force	N	36.0
Force Constant ±10%	N/Arms	8.1
Back EMF Constant ±10%	Vpeak/(m/s)	6.6
Motor Constant @25°C	N/Sqrt(W)	3.1
Resistance (L-L) @25°C ±10% <sup>③</sup>	Ω	4.51
Inductance (L-L) ±30% <sup>④</sup>	mH	0.58
Electrical Time Constant	ms	0.13
Continuous Current (NC) @100°C <sup>① ⑤</sup>	Arms	1.23
Stall Current (NC) @100°C <sup>① ②</sup>	Arms	1.03
Peak Current	Arms	4.4
Continuous Power Dissipation (NC) @100°C <sup>①</sup>	W	13.3
Max. Coil Temperature	°C	100.0
Thermal Dissipation Constant (NC) <sup>①</sup>	W/°C	0.18
Max. Bus Voltage	Vdc	60.0
Magnetic Period	mm	16.5
Attraction Force	N	0.0

- ① Measurement is taken at ambient temperature 25°C. Value depends on the thermal environment. Abbreviations: NC-Natural Cooling.
- ② Minimum heatsink area is 0.03m, and minimum speed is 10mm/s.
- ③ Resistance is measured by DC current with standard 0.5m cable.
- ④ Inductance is measured by current frequency of 1kHz.
- ⑤ Maximum continuous current should be limited to 1.0 Arms due to connector limitation. The contents of datasheet are subject to change without prior notice.

## Z-axis Linear Encoder

Specifications	ABI-21
Power Supply	5V ±10% 200mA (Max)
Output	TTL ABZ
Operating Temperature	0 °C to +70 °C
Humidity	10 to 80% @ RH (Non-Condensing)
Shock (Non-Operating)	<1000 m/s <sup>2</sup> , 6ms, ½ Sine
Vibration (Operating)	<100 m/s <sup>2</sup> Max @ 55 Hz to 2000 Hz
Scale Period	80 μm
Resolution	0.5 μm
Substrate Material	Nickel
Expansion Coefficient	14 ppm/°C

## T-axis Motor

Performance Parameters	Unit	TP12
Continuous Torque (NC) @100°C <sup>①</sup>	Nm	7.40E-03
Peak Torque	Nm	1.85E-02
Torque Constant ±10%	Nm/Arms	9.25E-03
Back EMF Constant ±10%	Vpeak/rpm	7.91E-04
Motor Constant @25°C	Nm/Sqrt(W)	4.66E-03
Resistance (L-L) @25°C ±10% <sup>②</sup>	Ω	2.63
Inductance (L-L) ±20% <sup>③</sup>	mH	0.23
Electrical Time Constant	ms	0.09
Continuous Current (NC) @100°C <sup>①</sup>	Arms	0.80
Peak Current	Arms	2.00
Continuous Power Dissipation (NC) @100°C <sup>①</sup>	W	3.25
Max. Coil Temperature	°C	100.0
Thermal Dissipation Constant (NC) <sup>①</sup>	W/°C	0.043
Max. Bus Voltage	Vdc	48.0
Pole Number	-	4
Max. Speed <sup>④</sup>	rpm	1000

- ① Measurement is taken at ambient temperature 25°C. Value depends on the thermal environment. Abbreviations: NC-Natural Cooling.
- ② Minimum heatsink area is 0.03m, and minimum speed is 10mm/s.
- ③ Resistance is measured by DC current with standard 0.5m cable.
- ④ Inductance is measured by current frequency of 1kHz. The contents of datasheet are subject to change without prior notice.

## T-axis Rotary Encoder

Specifications	ABI-2250 + INTERPOLATOR
Power Supply	5V ±5% 60mA (Typical)
Output	TTL ABZ
Operating Temperature	0 °C to +70 °C
Humidity	10 to 80% @ RH (Non-Condensing)
Shock (Non-Operating)	<1000 m/s <sup>2</sup> , 6ms, ½ Sine
Vibration (Operating)	<100 m/s <sup>2</sup> Max @ 55 Hz to 2000 Hz
Scale Period	80 μm
Resolution (2048x)	491520 counts/rev
Substrate Material	Aluminium
Expansion Coefficient	24 ppm/°C

## Ordering Part Number (OPN)

**APC16B-Z30**

Model:  
APC16B

Axis & Effective Stroke:  
Z30: Z-axis, 30mm  
ZT30: Z-axis, 30mm/T-axis, limitless

Note:  
★ Products can be customized to meet specific working environments, please contact cust-service@akribis-sys.com.

# APC16B-ZT30 & Z30 Pin Assignments

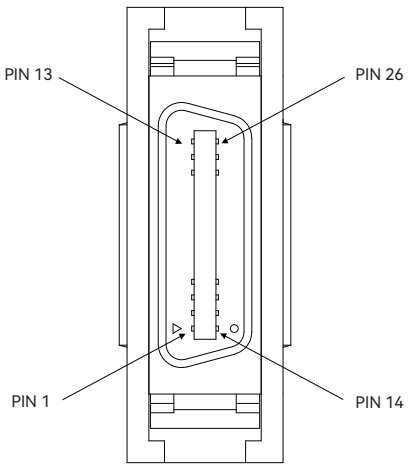
ENCODER CONNECTOR	PIN	SIGNAL
 <p>26-pin MDR Receptacle Mating Option: 3M 10226-0210EC</p>	1	Z_ENC_5V
	2	Z_ENC_0V
	3	Z_ENC_A+
	4	Z_ENC_A-
	5	Z_ENC_B+
	6	Z_ENC_B-
	7	Z_ENC_Z+
	8	Z_ENC_Z-
	9	NOT CONNECTED
	10	Z_ENC_0V
	11	Z_M1
	12	Z_M2
	13	Z_M3
	14	T_ENC_5V
	15	T_ENC_0V
	16	T_ENC_A+
	17	T_ENC_A-
	18	T_ENC_B+
	19	T_ENC_B-
	20	T_ENC_Z+
	21	T_ENC_Z-
	22	NOT CONNECTED
	23	PE
	24	T_M1
	25	T_M2
	26	T_M3