

AXM SERIES

- ▶ Compact size
- ▶ Direct drive brushless motor
- ▶ Fully integrated with encoder and bearing
- ▶ Low cogging torque
- ▶ Optional for low speed and high speed windings
- ▶ High torque density
- ▶ Built-in high precision grating scale

EN-26.3.1

AXM40-43

AXM40-43					
Performance Parameters		Symbol	Unit	Series	Parallel
Continuous Torque (NC) @100°C ❶		T _{cn}	Nm	0.11	0.11
Peak Torque		T _{pk}	Nm	0.30	0.30
Torque Constant ±10%		K _t	Nm/Arms	0.09	0.05
Back EMF Constant ±10%		K _e	Vpeak/rpm	0.008	0.004
Motor Constant @25°C		K _m	Nm/Sqrt(W)	0.03	0.03
Resistance (L-L) @25°C ±10% ❷		R ₂₅	Ω	7.6	1.9
Inductance (L-L) ±20% ❸		L	mH	6.8	1.7
Electrical Time Constant		τ _e	ms	0.9	0.9
Continuous Current (NC) @100°C ❹		I _{cn}	Arms	1.2	2.4
Peak Current		I _{pk}	Arms	4.9	9.8
Continuous Power Dissipation (NC) @100°C ❺		P _{cn}	W	22.0	22.0
Max. Coil Temperature		t _{max}	°C	100	100
Thermal Dissipation Constant (NC) ❻		K _{thn}	W/°C	0.29	0.29
Max. Bus Voltage		U _{bus}	Vdc	330	330
Pole Number		2P	-	10	10
Max Speed ❷		Ω _{max}	rpm	2500	5000
Mechanical Parameters					
Overall Mass (NC)		m _n	kg	0.24	0.24
Rotor Inertia		J _r	kg·m ²	1.18E-05	1.18E-05
Axial Runout ❸		-	μm	25	25
Radial Runout ❸		-	μm	25	25
Max Axial Load (Upright Mounting) ❹		-	N	20	20
Max Axial Load (Inverted / Wall Mounting)		-	N	6	6
Max Moment Load (Upright Mounting)		-	Nm	0.3	0.3
Max Moment Load (Inverted / Wall Mounting)		-	Nm	0.1	0.1
Encoder Parameters					
ABI Optical Incremental Encoder (SIN/COS)	-	lines / rev	650	650	
ABI Optical Incremental Encoder (80x)	-	counts / rev	52000	52000	
ABI Optical Incremental Encoder (160x)	-	counts / rev	104000	104000	
ABI Optical Incremental Encoder (400x)	-	counts / rev	260000	260000	
Accuracy after Error Mapping ❷	-	arc sec	+/-20	+/-20	
Repeatability ❸	-	arc sec	+/-10	+/-10	
Other Information					
Insulation Class	Class A (105°C)				
Protection Grade	IP40				
Compliance with Global Standards	Chinese RoHS, CE				
Ambient Temperature	Operation	0°C to 40°C (non-freezing)			
	Storage	-15°C to 70°C (non-freezing)			
Ambient Humidity	Operation	10%RH to 80%RH (non-condensing)			
	Storage	10%RH to 90%RH (non-condensing)			
Recommended Ambience	Indoor (no direct sunlight); No corrosive gas, inflammable gas, oil mist or dust.				

- ❶ Measurement is taken at ambient temperature 25°C. Value depends on the thermal environment.
 - ❷ Resistance is measured by DC current with standard 0.2 m cable.
 - ❸ Inductance is measured by current frequency of 1 kHz.
 - ❹ The value is based on ABI optical SIN/COS encoder (4096x interpolation) under max. bus voltage.
 - ❺ Runout specification define in the datasheet is based on constant loading and temperature condition (the value in parenthesis is optional).
 - ❻ Please refer to the illustration for different mountings.
 - ❼ Based on ABI optical SIN/COS encoder (4096x interpolation) with standard runout.
- The contents of datasheet are subject to change without prior notice.

Dimension

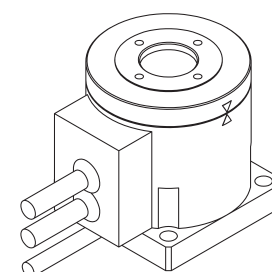
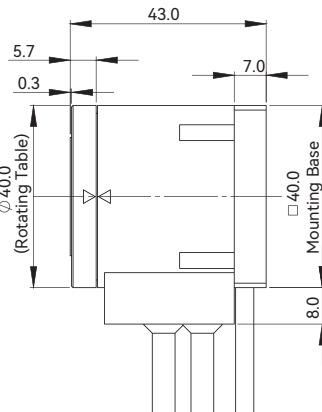
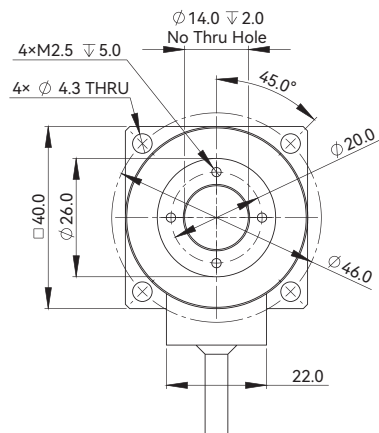

- Note:
- ❶ No centre through hole.
 - ❷ No temperature sensor.
 - ❸ Standard cable length = 200mm
 - ❹ ABI analog encoder

Motor cable, ϕ 5.0
Hall cable, ϕ 5.0
Encoder cable, ϕ 4.0
Cable length = 200mm

Torque-Speed Curve

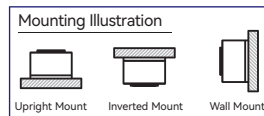
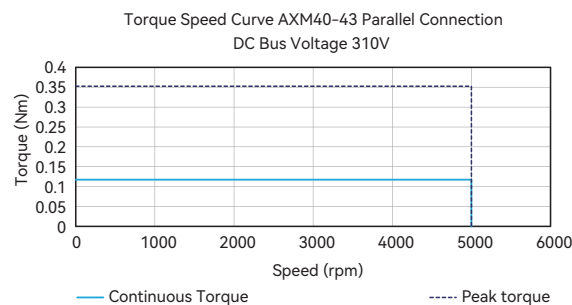
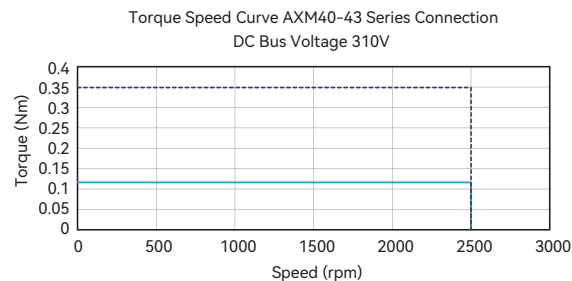

AXM60-50

Introduction Sizing Guide Frequently Asked Questions Linear Motors Voice Coil Motors Direct Drive Rotary Motors Magnet Spring Motion Control of Gantry Stages

AXM60-50				
Performance Parameters	Symbol	Unit	Series	Parallel
Continuous Torque (NC) @100°C ❶	T _{cn}	Nm	0.71	0.71
Peak Torque	T _{pk}	Nm	2.00	2.00
Torque Constant ±10%	K _t	Nm/Arms	0.47	0.24
Back EMF Constant ±10%	K _e	Vpeak/rpm	0.040	0.020
Motor Constant @25°C	K _m	Nm/Sqrt(W)	0.11	0.11
Resistance (L-L) @25°C ±10% ❷	R ₂₅	Ω	12.8	3.2
Inductance (L-L) ±20% ❸	L	mH	28.5	7.1
Electrical Time Constant	τ _e	ms	2.2	2.2
Continuous Current (NC) @100°C ❶	I _{cn}	Arms	1.5	3.0
Peak Current	I _{pk}	Arms	6.0	12.0
Continuous Power Dissipation (NC) @100°C ❶	P _{cn}	W	55.9	55.9
Max. Coil Temperature	t _{max}	°C	100	100
Thermal Dissipation Constant (NC) ❶	K _{thn}	W/°C	0.75	0.75
Max. Bus Voltage	U _{bus}	Vdc	330	330
Pole Number	2P	-	10	10
Max Speed ❹	Ω _{max}	rpm	1750	3500
Mechanical Parameters				
Overall Mass (NC)	m _n	kg	0.64	0.64
Rotor Inertia	J _r	kg m ²	7.38E-05	7.38E-05
Axial Runout ❺	-	μm	25	25
Radial Runout ❻	-	μm	25	25
Max Axial Load (Upright Mounting) ❷	-	N	50	50
Max Axial Load (Inverted / Wall Mounting)	-	N	15	15
Max Moment Load (Upright Mounting)	-	Nm	0.7	0.7
Max Moment Load (Inverted / Wall Mounting)	-	Nm	0.2	0.2
Encoder Parameters				
ABI Optical Incremental Encoder (SIN/COS)	-	lines / rev	650	650
ABI Optical Incremental Encoder (80x)	-	counts / rev	52000	52000
ABI Optical Incremental Encoder (160x)	-	counts / rev	104000	104000
ABI Optical Incremental Encoder (400x)	-	counts / rev	260000	260000
Accuracy after Error Mapping ❷	-	arc sec	+/-20	+/-20
Repeatability ❷	-	arc sec	+/-10	+/-10
Other Information				
Insulation Class	Class A (105°C)			
Protection Grade	IP40			
Compliance with Global Standards	Chinese RoHS, CE			
Ambient Temperature	Operation	0°C to 40°C (non-freezing)		
	Storage	-15°C to 70°C (non-freezing)		
Ambient Humidity	Operation	10%RH to 80%RH (non-condensing)		
	Storage	10%RH to 90%RH (non-condensing)		
Recommended Ambience	Indoor (no direct sunlight); No corrosive gas, inflammable gas, oil mist or dust.			

- ❶ Measurement is taken at ambient temperature 25°C. Value depends on the thermal environment.
- ❷ Resistance is measured by DC current with standard 0.2 m cable.
- ❸ Inductance is measured by current frequency of 1 kHz.
- ❹ The value is based on ABI optical SIN/COS encoder (4096x interpolation) under max. bus voltage.
- ❺ Runout specification define in the datasheet is based on constant loading and temperature condition (the value in parenthesis is optional).
- ❻ Please refer to the illustration for different mountings.
- ❼ Based on ABI optical SIN/COS encoder (4096x interpolation) with standard runout.
The contents of datasheet are subject to change without prior notice.

Dimension

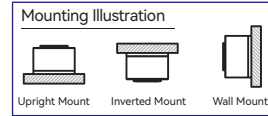
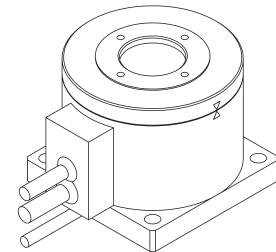
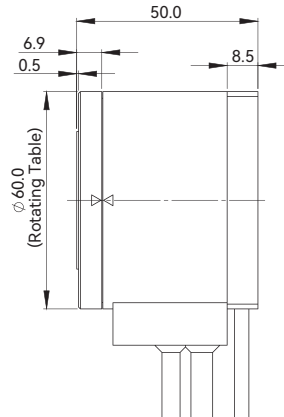
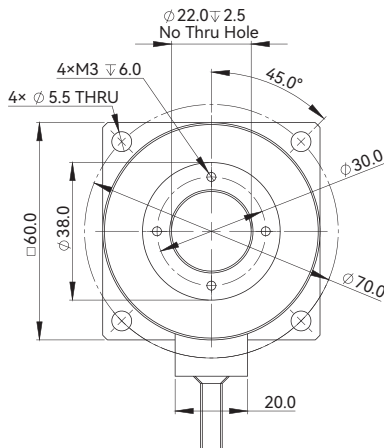

Torque-Speed Curve

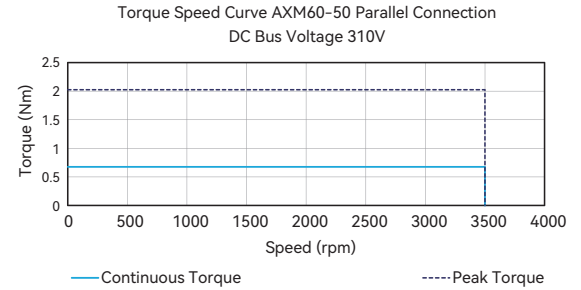
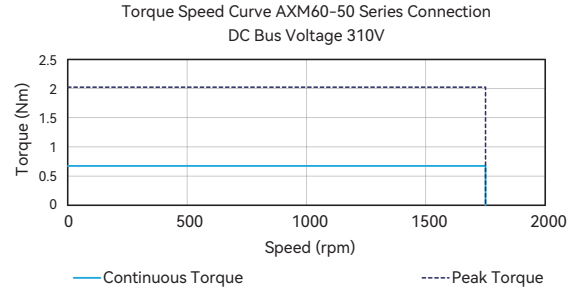

- Note:
- ❶ No centre through hole.
 - ❷ No temperature sensor.
 - ❸ Standard cable length = 200mm
 - ❹ ABI analog encoder

Motor cable, ϕ 5.0
Hall cable, ϕ 5.0
Encoder cable, ϕ 4.0
Cable length = 200mm

Motor Cable Connection

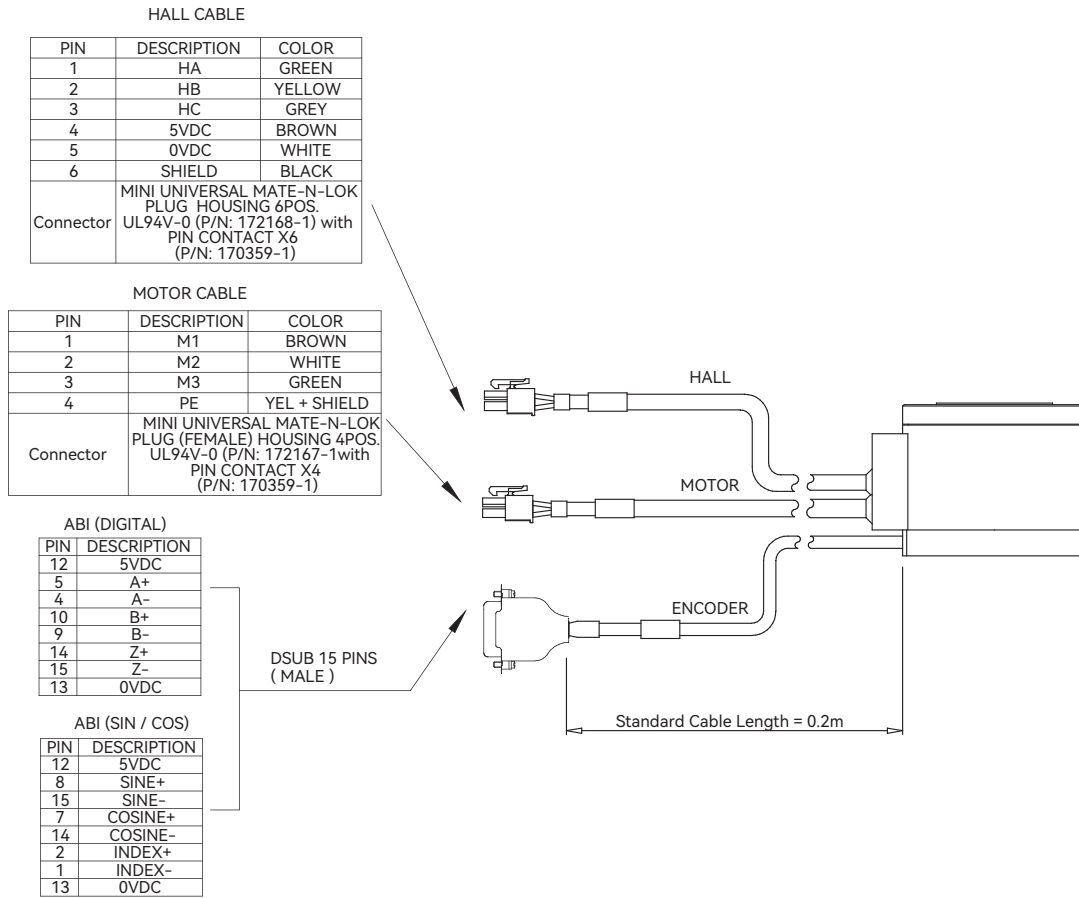

Part Numbering

