

PGS-ZTPR SERIES

- ▶ Frictionless guidance with wear-free flexure bearings
- ▶ Tight integration provides 4 degrees of freedom (Z, Rx, Ry, Rz) motion in a compact and lightweight package
- ▶ Optimized dynamics for rapid move and settle and nanometric position stability
- ▶ Vacuum feedthrough channel to chuck available
- ▶ Suitable for wafer autofocus, levelling, and alignment in a wide range of inspection and metrology applications

EN-26.3.1

PGS-ZTPR

Motor Specifications	Payload Mass: 1.4-2.0 kg PGS-ZTPR--1-_-_-_- PGS-ZTPR--2-_-_-_-		Payload Mass: 2.0-2.5 kg PGS-ZTPR--3-_-_-_- PGS-ZTPR--4-_-_-_-	
	For Z, Rx and Ry axis			
Motor	AVMG40-5-0.5		AVM040-G-050-005-F-001	
Continuous Force (NC) @100°C ^① ^②	8.1 N		8.5 N	
Peak Force ^②	20.0 N		20.9 N	
Force Constant ±10% ^②	8.1 N/A		8.5 N/A	
Back EMF Constant ±10% ^②	8.1 V/(m/s)		8.5 V/(m/s)	
Resistance @25°C ±10% ^③	7.3 Ω		7.3 Ω	
Inductance ±20% ^④	2.9 mH		2.9 mH	
Continuous Current (NC) @100°C ^①	1.0 A		1.0 A	
Peak Current	2.5 A		2.5 A	
Max. Voltage	48 Vdc		48 Vdc	
For Rz axis				
Motor	ACW130-P14-P-K-NH-0.1-NFB-Z25			
Continuous Torque (NC) @130°C ^①	2.4 Nm			
Peak Torque	8.3 Nm			
Torque Constant ±10%	0.55 Nm/Arms			
Back EMF Constant ±10%	0.047 Vpeak/rpm			
Resistance (L-L) @25°C ±10% ^③	2.20 Ω			
Inductance (L-L) ±20% ^④	1.4 mH			
Continuous Current (NC) @130°C ^①	4.3 Arms			
Peak Current	15 Arms			
Max. Bus Voltage	90 Vdc			
Pole Number, 2p	16			
For Lift Pin				
Motor	Permanent Magnet DC Stepper Motor			
Phase	2			
Step Angle	7.5°			
Rated Current	0.35 A			
Resistance @20°C ±10%	14 Ω			
Coil Type	Bi-Polar			
Max. Bus Voltage	24 Vdc			
Mechanical Specifications	Z	Rx,Ry	Rz	Lift Pin
Effective Stroke	4 mm	±0.5 mrad	360° or 270° ^⑤	10 mm
Resolution	SINCOS	SINCOS	0.019 arcsec	-
Unidirectional Repeatability	±0.05 μm	-	-	±30 μm
Bidirectional Repeatability	±0.075 μm	-	±3 arcsec	-
Typical RMS Standstill Jitter (1σ), 1 kHz Cutoff	3.33 nm	0.01 arcsec	0.083 arcsec	-
Face Runout Repeatability (at R = 140mm)	-	-	±0.75 μm	-
Radial Runout Repeatability	-	-	±0.75 μm	-
Rated Payload	1.4 - 2.5 kg ^⑥			0.15 kg
Max. Acceleration (Depends on Payload)	2 m/s ²	-	10000 deg/s ²	-
Max. Velocity (Depends on Payload)	0.1 m/s	-	720 deg/s	-
Typical Move and Settle Time (With 1.5 kg Payload)	1 μm to ±50 nm in 20 ms 100 μm to ±50 nm in 50 ms 1 μm to ±30 nm in 50 ms 100 μm to ±30 nm in 90 ms	-	1° to ±0.4 arcsec in 100 ms 120° to ±0.4 arcsec in 400 ms 180° to ±0.4 arcsec in 1 s	10 mm in 2 s
Module Mass (Depends on Model)	6 - 8 kg			
Surface Finish	Black or clear anodized options			

① Measurement is taken at ambient temperature 25°C. Value depends on the thermal environment.
 ② The values are at mid stroke.
 ③ Resistance is measured by DC current with standard 3 m cable.
 The contents of datasheet are subjected to change without prior notice.

④ Inductance is measured by current frequency of 1 kHz.
 ⑤ The Rz effective stroke for the module with lift pin option is 200°, hard stop stroke is typically 250°.
 ⑥ Design needs to be customized to match payload mass, please contact cust-service@akribis-sys.com.

Dimensional Drawing

Rz (THETA) EFFECTIVE STROKE ±70 deg (HARD STOP STROKE 274.7 deg NOM.)
 COUNTER-CLOCKWISE +170 deg NOM. (HARD STOP +170.50 deg NOM.)
 CLOCKWISE -100 deg NOM. (HARD STOP -104.20 deg NOM.)

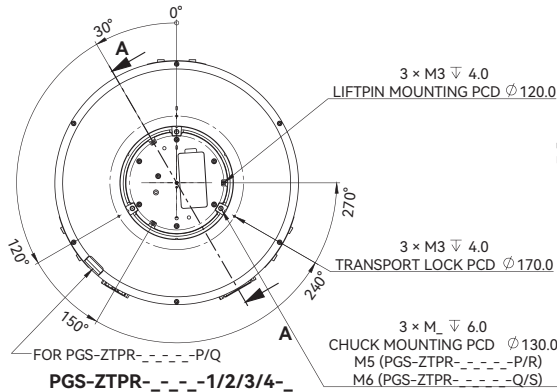

Rz (THETA) EFFECTIVE STROKE ±60 deg

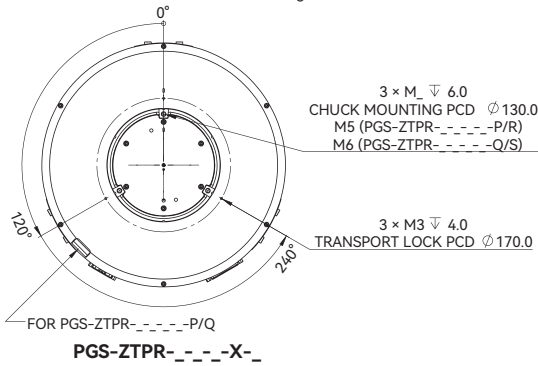

DISTANCE BETWEEN LIFTPIN AND CHUCK MOUNTING SURFACE
 LIFTPIN EFFECTIVE STROKE +/- 5.0mm
 LIFTPIN HARD STOP STROKE +/- 5.5mm TYP.

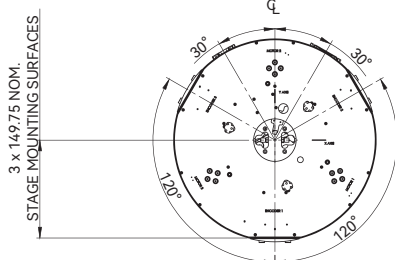
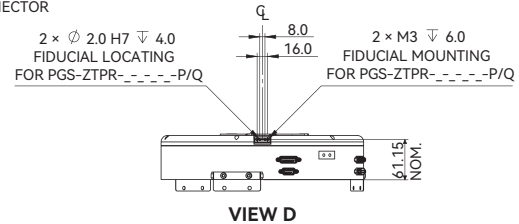
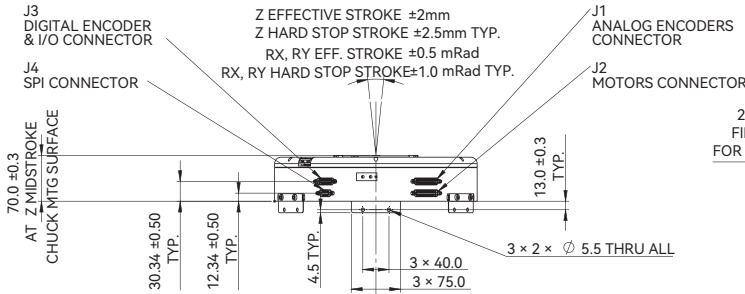
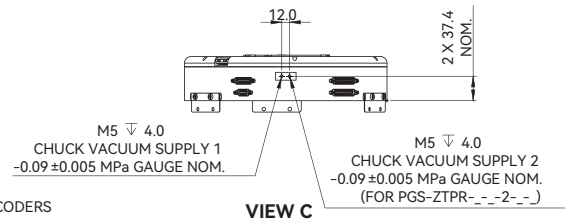
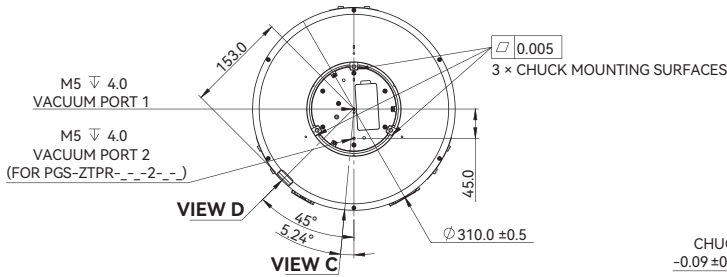
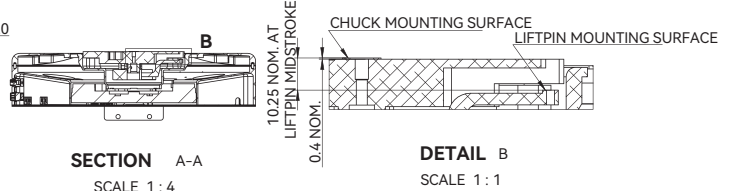

J1 ANALOG ENCODERS CONNECTOR

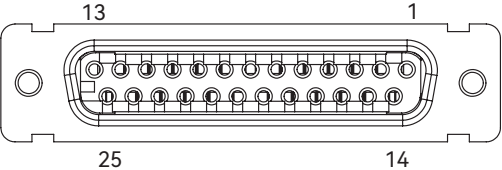
J1 ANALOG ENCODERS CONNECTOR	PIN	SIGNAL	REMARKS
 <p>DB-25 FEMALE CONTACT FINISH: GOLD SHELL FINISH: TIN 4-40 FEMALE THREADED</p> <p>RECOMMENDED MATING COMPONENTS: • 3M 8325-7000</p>	1	Z1_+5V	Z1 ENCODER POWER SUPPLY
	2	Z1_SIN+	Z1 ENCODER SIN NON-INVERTED
	3	Z1_COS+	Z1 ENCODER COS NON-INVERTED
	4	Z1_IND+	Z1 ENCODER INDEX NON-INVERTED
	5	Z2_+5V	Z2 ENCODER POWER SUPPLY
	6	Z2_SIN+	Z2 ENCODER SIN NON-INVERTED
	7	Z2_COS+	Z2 ENCODER COS NON-INVERTED
	8	Z2_IND+	Z2 ENCODER INDEX NON-INVERTED
	9	Z3_+5V	Z3 ENCODER POWER SUPPLY
	10	Z3_SIN+	Z3 ENCODER SIN NON-INVERTED
	11	Z3_COS+	Z3 ENCODER COS NON-INVERTED
	12	Z3_IND+	Z3 ENCODER INDEX NON-INVERTED
	13	PE	PROTECTIVE EARTH
	14	Z1_0V	Z1 ENCODER POWER SUPPLY RETURN
	15	Z1_SIN-	Z1 ENCODER SIN INVERTED
	16	Z1_COS-	Z1 ENCODER COS INVERTED
	17	Z1_IND-	Z1 ENCODER INDEX INVERTED
	18	Z2_0V	Z2 ENCODER POWER SUPPLY RETURN
	19	Z2_SIN-	Z2 ENCODER SIN INVERTED
	20	Z2_COS-	Z2 ENCODER COS INVERTED
	21	Z2_IND-	Z2 ENCODER INDEX INVERTED
	22	Z3_0V	Z3 ENCODER POWER SUPPLY RETURN
	23	Z3_SIN-	Z3 ENCODER SIN INVERTED
	24	Z3_COS-	Z3 ENCODER COS INVERTED
	25	Z3_IND-	Z3 ENCODER INDEX INVERTED
	CASE	SHIELD	-

J2 MOTORS CONNECTOR

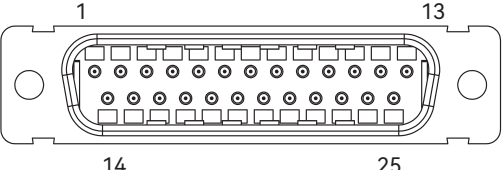
J2 MOTORS CONNECTOR	PIN	SIGNAL	REMARKS
 <p>DB-25 MALE CONTACT FINISH: GOLD SHELL FINISH: TIN 4-40 FEMALE THREADED</p> <p>RECOMMENDED MATING COMPONENTS: • 3M 8325-7000</p>	1	PE	PROTECTIVE EARTH
	2	T_M3	THETA MOTOR PHASE 3
	3	T_M2	THETA MOTOR PHASE 2
	4	T_M1	THETA MOTOR PHASE 1
	5	PE	PROTECTIVE EARTH
	6	LP_STEP_B	LIFT PIN STEPPER MOTOR PHASE B
	7	LP_STEP_A	LIFT PIN STEPPER MOTOR PHASE A
	8	PE	PROTECTIVE EARTH
	9	Z3_M-	Z3 MOTOR TERMINAL 2
	10	PE	PROTECTIVE EARTH
	11	Z2_M-	Z2 MOTOR TERMINAL 2
	12	PE	PROTECTIVE EARTH
	13	Z1_M-	Z1 MOTOR TERMINAL 2
	14	PE	PROTECTIVE EARTH
	15	T_M3	THETA MOTOR PHASE 3
	16	T_M2	THETA MOTOR PHASE 2
	17	T_M1	THETA MOTOR PHASE 1
	18	LP_STEP_B'	LIFT PIN STEPPER MOTOR PHASE B'
	19	LP_STEP_A'	LIFT PIN STEPPER MOTOR PHASE A'
	20	PE	PROTECTIVE EARTH
	21	Z3_M+	Z3 MOTOR TERMINAL 1
	22	PE	PROTECTIVE EARTH
	23	Z2_M+	Z2 MOTOR TERMINAL 1
	24	PE	PROTECTIVE EARTH
	25	Z1_M+	Z1 MOTOR TERMINAL 1
	CASE	SHIELD	-

J3 DIGITAL ENCODER & I/O CONNECTOR

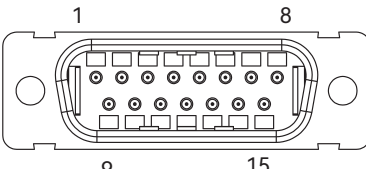
J3 DIGITAL ENCODER & I/O CONNECTOR	PIN	SIGNAL	REMARKS
 <p>DA-15 MALE CONTACT FINISH: GOLD SHELL FINISH: TIN 4-40 FEMALE THREADED</p> <p>RECOMMENDED MATING COMPONENTS: • 3M 8315-7000</p>	1	CVAC_VALV_2	CHUCK VACUUM VALVE CONTROL SIGNAL PORT 2
	2	LP_LIM_SUPRET	LIFT PIN LIMIT SWITCH POWER SUPPLY RETURN
	3	CVAC_VALV_1	CHUCK VACUUM VALVE CONTROL SIGNAL PORT 1
	4	T_MA+	THETA ENCODER CLOCK NON-INVERTED
	5	T_SL+	THETA ENCODER SIGNAL NON-INVERTED
	6	T_+5V	THETA ENCODER POWER SUPPLY
	7	I/O_0V	I/O POWER SUPPLY RETURN
	8	I/O_+24V	I/O POWER SUPPLY
	9	LP_LIM_DARKON / LP_LLIM_DARKON	LIFT PIN LIMIT SWITCH DARK-ON (FOR PGS-ZTPR-_-_-X/1/3-_) / LIFT PIN BOTTOM LIMIT SWITCH DARK-ON (FOR PGS-ZTPR-_-_-2/4-_)
	10	LP_LIM_SUP	LIFT PIN LIMIT SWITCH POWER SUPPLY
	11	T_MA-	THETA ENCODER CLOCK INVERTED
	12	T_SL-	THETA ENCODER SIGNAL INVERTED
	13	T_0V	THETA ENCODER POWER SUPPLY RETURN
	14	I/O_0V	I/O POWER SUPPLY RETURN
	15	I/O_+24V / LP_RLIM_DARKON	I/O POWER SUPPLY (FOR PGS-ZTPR-_-_-X/1/3-_) / LIFT PIN TOP LIMIT SWITCH DARK-ON (FOR PGS-ZTPR-_-_-2/4-_)
CASE	SHIELD	-	

J4 SPI CONNECTOR

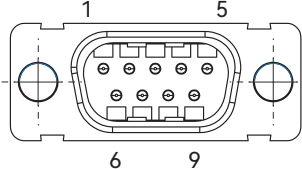
J4 SPI CONNECTOR	PIN	SIGNAL	REMARKS
 <p>DE-9 MALE CONTACT FINISH: GOLD SHELL FINISH: TIN 4-40 FEMALE THREADED</p> <p>RECOMMENDED MATING COMPONENTS: • 3M 8309-7000</p>	1	PE	PROTECTIVE EARTH
	2	SPI_SS+	SPI SLAVE SELECT NON-INVERTED
	3	SPI_SCLK-	SPI CLOCK INVERTED
	4	SPI_MISO-	SPI MASTER IN/SLAVE OUT INVERTED
	5	SPI_MOSI+	SPI MASTER OUT/SLAVE IN NON-INVERTED
	6	SPI_SS-	SPI SLAVE SELECT INVERTED
	7	SPI_MISO+	SPI MASTER IN/SLAVE OUT NON-INVERTED
	8	SPI_SCLK+	SPI CLOCK NON-INVERTED
	9	SPI_MOSI-	SPI MASTER OUT/SLAVE IN INVERTED
CASE	SHIELD	-	

Ordering Part Number (OPN)

PGS-ZTPR-C-1-1-1-P

Model:
PGS-ZTPR

Finish:
C: Clear Anodized
B: Black Anodized

Payload Mass:
1: 1.4-1.7kg
2: 1.7-2.0kg
3: 2.0-2.3kg
4: 2.3-2.5kg

Chuck Interface Option:

P: M5 Tapped Holes with Fiducial Arm
Q: M6 Tapped Holes with Fiducial Arm
R: M5 Tapped Holes without Fiducial Arm
S: M6 Tapped Holes without Fiducial Arm

Lift Pin Module Option:

X: None
1: Indirect Drive Lift Pin 10mm Travel Single Limit (NPN)
2: Indirect Drive Lift Pin 10mm Travel Dual Limits (NPN)
3: Indirect Drive Lift Pin 10mm Travel Single Limit (PNP)
4: Indirect Drive Lift Pin 10mm Travel Dual Limits (PNP)

Vacuum Supply to Chuck Interface:

1: Single Channel
2: Dual Channel

Note:

★ Products can be customized to meet specific working environments, please contact cust-service@akribis-sys.com.