

# CNC DIRECT DRIVE ROTARY TABLE

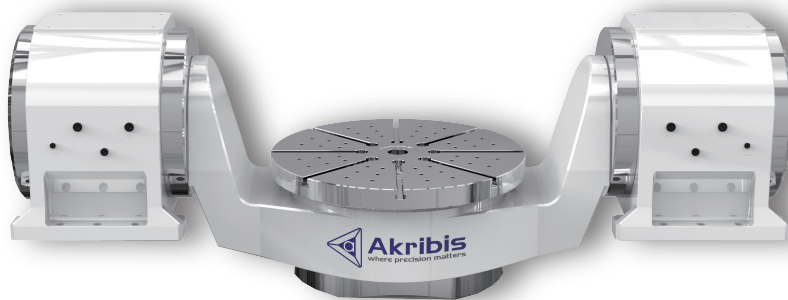

**where precision matters**

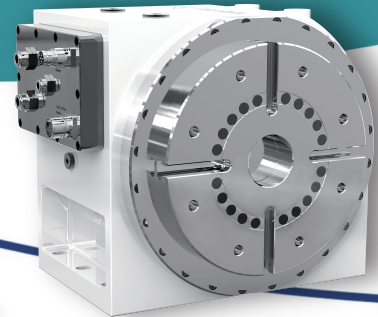
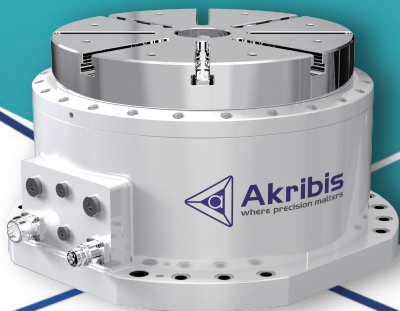

Akribis is a Latinized Greek word that means “Precision”. On the Akribis logo, the letter “a” is formed by a line and a circle, representing linear and rotary motions. These are supported by a tetrahedron structure, the same structure as the diamond crystal which has many exceptional physical properties.

The logo signifies that Akribis Systems’ sound engineering expertise forms the cornerstone of the company, and this enables us to provide customers with precise, direct drive motion control solutions.

Akribis Systems Pte. Ltd. was founded in 2004. We design and manufacture direct drive motors, stages and precision systems that are used in equipment for manufacturing, inspection and testing. Akribis Systems supports a wide range of industries including semiconductor, solar, flat panel, hard disk, LED, printed circuit board, printing, photonics and biomedical manufacturing.

From the beginning, the company has been focusing on innovation and development of new technologies and solutions in motion control, with more than 134 patents applied. Backed by a very strong and committed engineering team, the company continues to develop custom motors and systems for demanding applications.

We have manufacturing facilities in Singapore; Shanghai, Nantong and Dongguan (China); Selangor (Malaysia); and Siheung (Korea). Our sales network includes our sales offices in USA, Germany, South Korea, India, Thailand, Israel and Malaysia, and is reinforced by our comprehensive distribution channels in Asia, Europe and North America.



# CONTENTS

## 1 - Introduction

Why Choose a Direct Drive Rotary Table .....	04
Why Choose Akribis .....	05

## 2 - Direct Drive Rotary Table

ATRT Series .....	06-10
ARH Series .....	11-14
ARV Series .....	15-19

# Why Choose a Direct Drive Rotary Table

A direct-drive rotary table refers to a rotary table driven by a torque motor, where the load is directly connected to the rotor of the torque motor without any intermediate transmission mechanism.

## Comparison between Direct Drive Rotary Tables and Conventional Rotary Tables

Contrastive contents	Ordinary Turntable	DD Turntable
<b>Mechanical accuracy</b>	Transmission error, backlash and thermal deformation exist	<b>No transmission error, no backlash and water cooling</b>
<b>Positioning accuracy</b>	±15"	<b>±4"</b>
<b>Structural volume</b>	Complex and bulky	<b>Simple and compact</b>
<b>Speed</b>	Low speed and acceleration	<b>High speed and acceleration</b>
<b>Time required for 90° positioning</b>	0.5s	<b>0.1s</b>
<b>Responsiveness</b>	0.1s	<b>5ms</b>
<b>Accuracy life</b>	1 to 3 years	<b>More than 5 years</b>

Akribis 4-axis / 5-axis turntable is driven by direct drive motors, which has similar continuous torque compared with traditional transmission methods such as worm gear, roller cam, and reducer, while the speed, accuracy and accuracy life are greatly improved.

The product uses YRT special bearing, which has high axial and radial bearing capacity, and can bear two-way axial load, radial load and overturning moment simultaneously. The rotary table features a water-cooling design, which not only effectively reduces thermal deformation but also increases torque output while enhancing the responsiveness and precision of the table. With zero backlash and zero wear characteristics, the rotary table delivers high reliability and significantly lowers maintenance costs. The rotary table is equipped with a high-precision encoder and is compatible with most CNC systems.

Akribis's 4-axis and 5 axis turntable is also used in 5-axis machining centres, tool grinder, compound grinder, worm grinder, vertical grinder, turn-milling compound and other high precision grinding machines.



# Why Choose Akribis

## Brand Positioning

Akribis focuses on direct drive technology and has long been deeply engaged in the field of direct drive for machine tools. We provide high-performance, highly stable direct drive solutions to machine tool manufacturers worldwide, helping our customers enhance their core competitiveness.

## High Quality

Akribis implements a full-process quality management system and strictly adheres to quality control standards. We have obtained numerous internationally recognized certifications including RoHS and ISO, and has established a comprehensive compliance certification system covering CE, UL, OHSAS and other standards, ensuring product quality, safety and reliability through stringent requirements.

## Customized

In response to differences in size, precision and operating conditions among various machine tools, Akribis have set up dedicated teams to provide full-process customized services ranging from demand research, solution design to mass production.

# ATRT Series

## Dual Axis CNC Turntable



Direct drive technology, compact design

Fast dynamic response, wear-free, zero backlash

High torque density, high acceleration

High speed for continuous processing

Self-developed clamping system, applicable for 3+2 machining

High precision encoder compatible with various CNC systems

The cast iron housing with special metal composition combines hardness, strength and rigidity

Applicable to 5-axis machining

## ATRT200

Specifications	Unit	Rotation Axis / C Axis	Swivel Axis / A Axis
Diameter	mm	200	
Table to A-axis Distance	mm	30	
Max. Swivel Angle	deg	N*360	±110
Continuous Torque	Nm	45	170
Peak Torque	Nm	127	462
Max. Speed	rpm	200	120
Continuous Current	Arms	4.5	11
Peak Current	Arms	13.9	33.1
Clamping Mode	/	Pneumatic - Normally Open	Pneumatic - Normally Open
Clamping Torque	Nm	180 (6bar)	420 (6bar)
Accuracy	arcsec	8 (VDI)	8 (VDI)
Repeatability	arcsec	4 (VDI)	4 (VDI)
Max. Payload	Kg	80	
Net Weight	Kg	≤160	

### ■ Dimensional Drawing

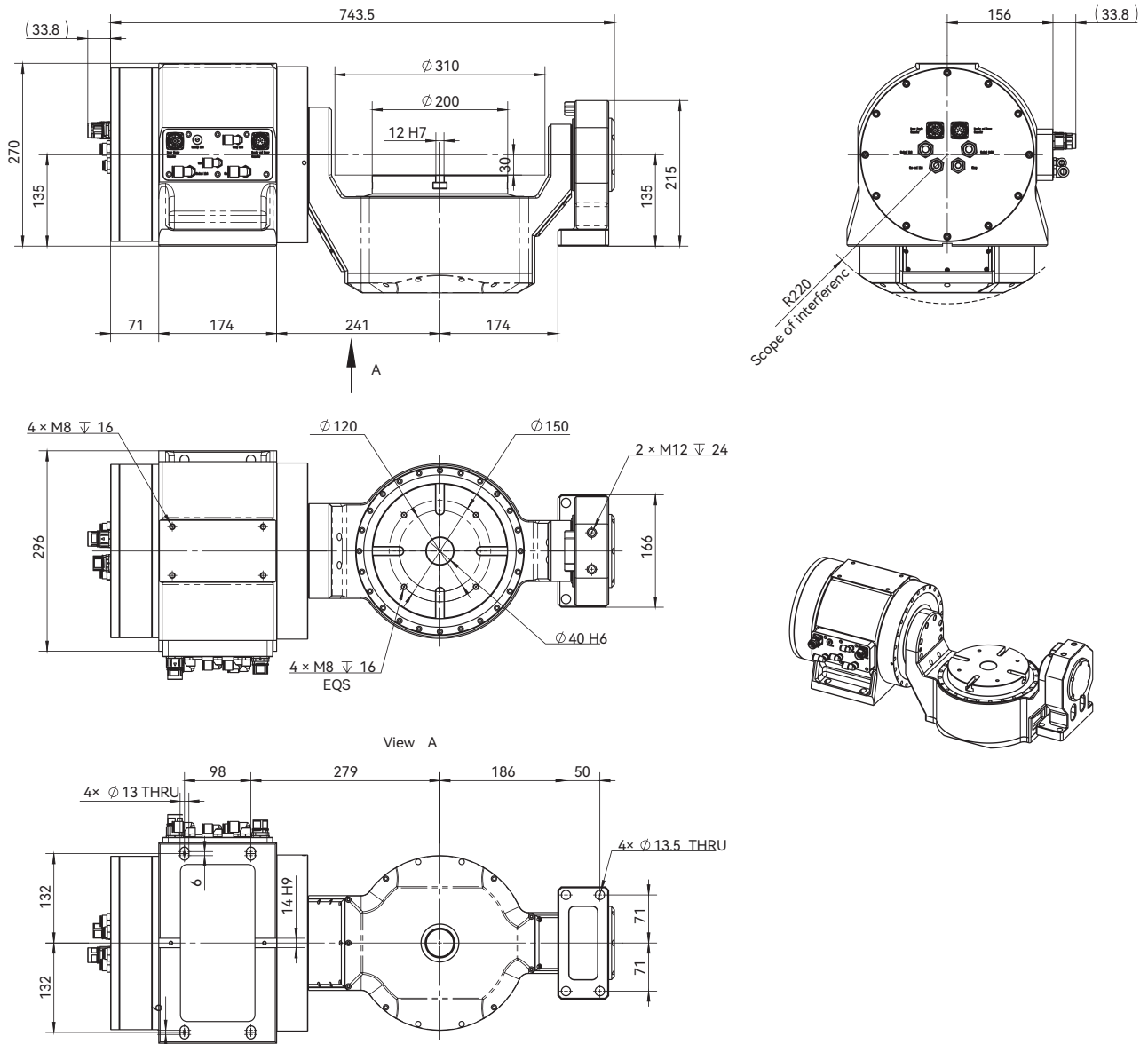

## ATRT350

Specifications	Unit	Rotation Axis / C Axis	Swivel Axis / A Axis
Diameter	mm	350	
Table to A-axis Distance	mm	50	
Max. Swivel Angle	deg	N*360	±120
Continuous Torque	Nm	190	470
Peak Torque	Nm	523	1400
Max. Speed	rpm	100	60
Continuous Current	Arms	11.3	22
Peak Current	Arms	35.6	74.6
Clamping Mode	/	Pneumatic - Normally Closed	Pneumatic - Normally Closed
Clamping Torque	Nm	750 (0bar)	750 (0bar)
		1380 (6bar)	1380 (6bar)
Accuracy	arcsec	10 (VDI)	10 (VDI)
Repeatability	arcsec	5 (VDI)	5 (VDI)
Max. Payload	Kg	300	
Net Weight	Kg	≤350	

### ■ Dimensional Drawing

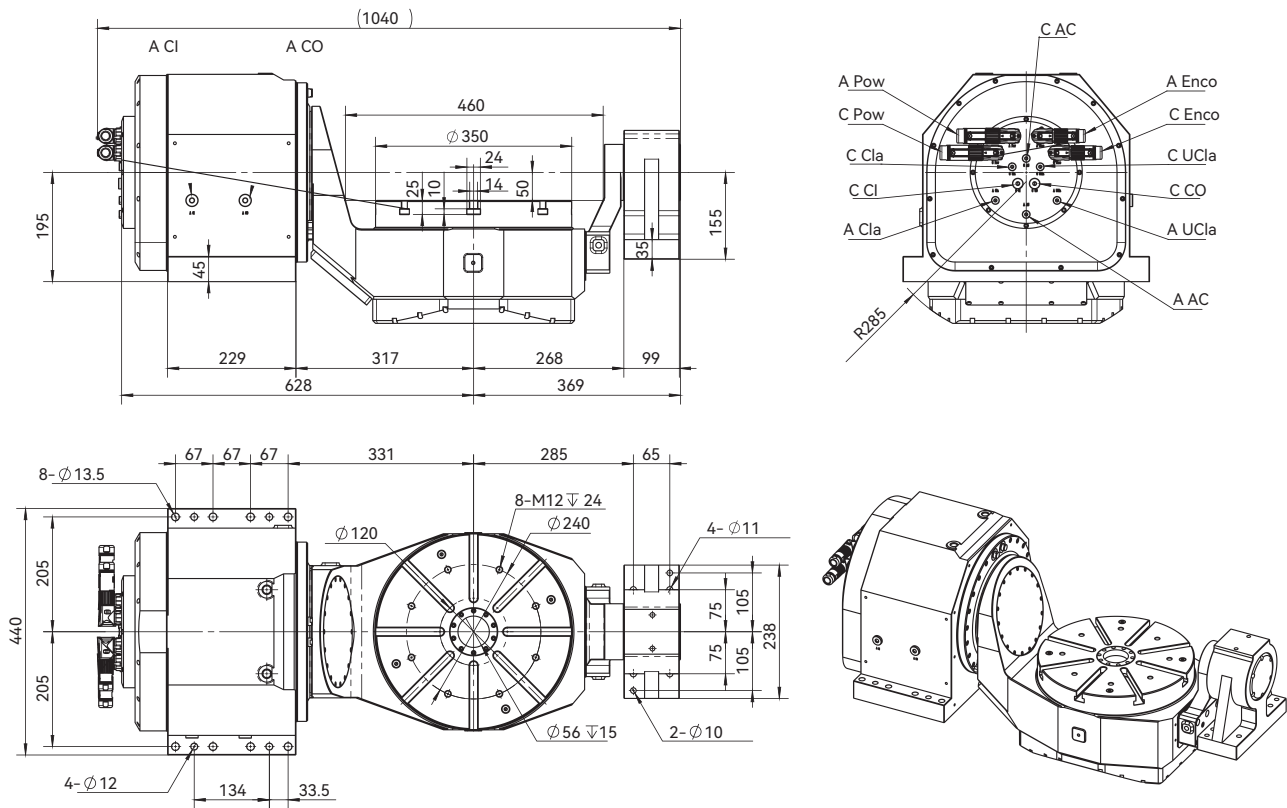

## ATRT630

Specifications	Unit	Rotation Axis / C Axis	Swivel Axis / A Axis
Diameter	mm	630	
Table to A-axis Distance	mm	100	
Max. Swivel Angle	deg	N*360	±110
Continuous Torque	Nm	928	2000
Peak Torque	Nm	1650	4600
Max. Speed	rpm	100	60
Continuous Current	Arms	26.9	2*29.7
Peak Current	Arms	50.4	2*65
Clamping Mode	/	Pneumatic - Normally Closed	Pneumatic - Normally Closed
Clamping Torque	Nm	2100 (0bar)	2800 (0bar)
		3120 (6bar)	5000 (6bar)
Accuracy	arcsec	10 (VDI)	10 (VDI)
Repeatability	arcsec	5 (VDI)	5 (VDI)
Max. Payload	Kg	600	
Net Weight	Kg	≤1500	

### Dimensional Drawing

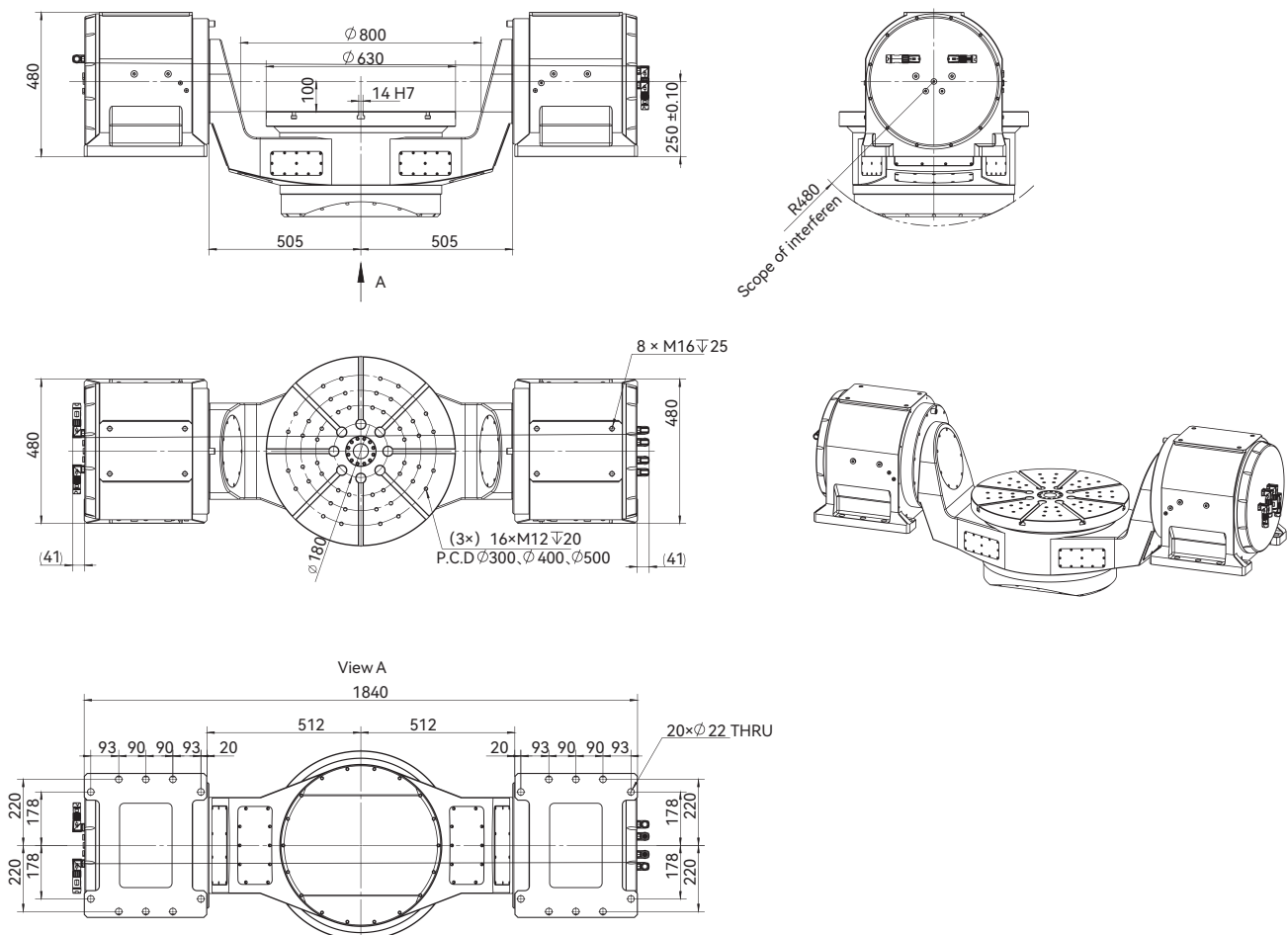

# ATRT Series

## Ordering Part Number (OPN)

**ATRT350S-L50-B10A00-100KT-000**

**Type:**

ATRT: Two-axis orthogonal turntable

**Design Control Code:**

000: Standard

**Diameter:**

200: Table diameter 200mm  
350: Table diameter 350mm  
630: Table diameter 630mm

**Thermal Sensor:**

K: PT100  
KT: PT100+KTY84  
DE: PT1000+SNM(PTC)

**Installation Feature:**

N: Single motor without support  
S: Single motor with support  
M: Dual motors

**Max speed:**

100: Max speed: 100rpm

**Distance between the table and the A axis:**

L: The table is below the A axis  
H: The table is higher than the A axis  
50: Distance between the table and the A axis 50mm  
100: Distance between the table and the A axis 100mm

**Cable:**

00: Aviation sockets  
30: 3m Flying leads  
40: 4m Flying leads  
...  
90: 9m Flying leads  
99: 10m Flying leads

**Encoder Protocols:**

B: Biss-C  
S: SSI  
E: Endat2.2  
D: Drive-CLiQ

**Clamping:**

A: Pneumatic clamping  
H: Hydraulic clamping  
X: No clamping

**Accuracy:**

5: Radial Runout: 0.005mm, Axial Runout: 0.005/300mm  
10: Radial Runout: 0.010mm, Axial Runout: 0.01/0300mm

**Note:**

- ① For other agreements, please consult for customization.
  - ② For higher precision, please consult for customization.
  - ③ Please consult customization for cord outlet and plug.
- For more options, please consult [cust-service@akribis-sys.com](mailto:cust-service@akribis-sys.com)

# ARH Series Horizontal CNC Turntable

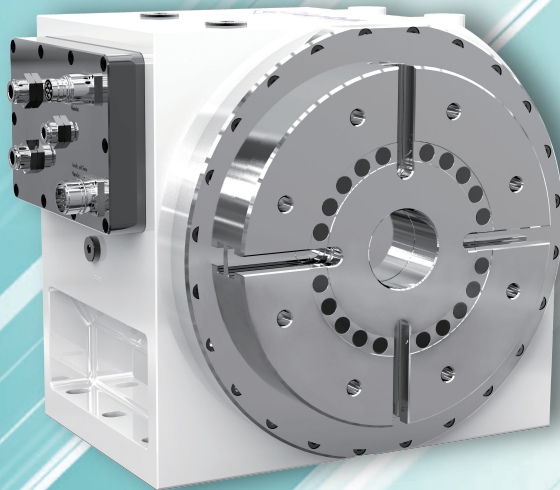

Direct drive technology, compact design

Fast dynamic response, wear-free, zero backlash

High torque density, high acceleration

High-speed continuous machining

Self-developed clamping system, enabling positioning and machining at any angle

High precision encoder compatible with various CNC systems

Fourth axis for CNC machining centers

Applicable to workpiece rotation shaft of various special machine tools such as grinding, milling and turning

## VRT7050

Specifications	Unit	VRT7050
Diameter	mm	105
Center Height	mm	150
Continuous Torque	Nm	58
Peak Torque	Nm	155
Max. Speed	rpm	250
Continuous Current	Arms	6
Peak Current	Arms	18
Center Hole	/	BT50, Schaublin-W25
Clamping Mode	/	/
Clamping Torque	Nm	/
Accuracy	arcsec	8 (VDI)
Repeatability	arcsec	4 (VDI)
Max. Payload	Kg	50
Net Weight	Kg	≤70

### ■ Dimensional Drawing

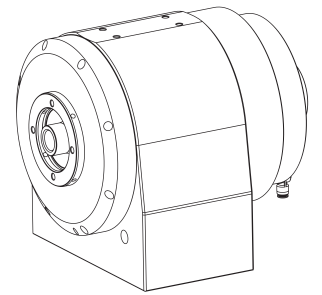
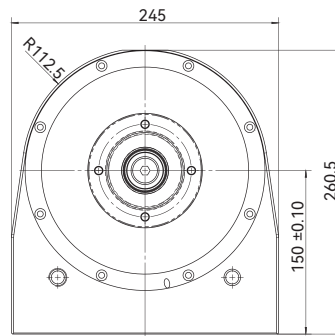
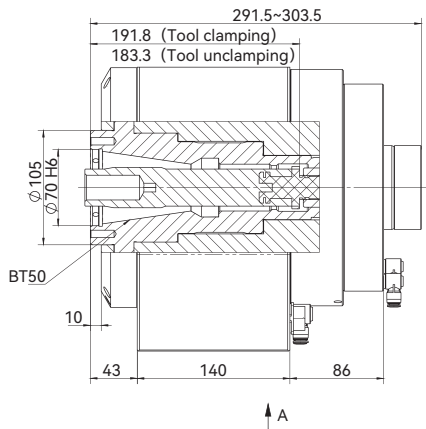

View A

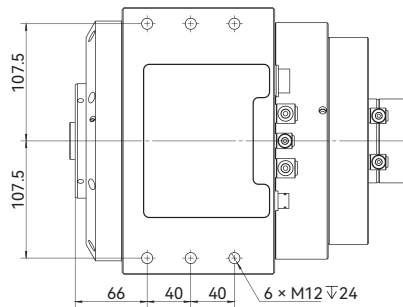
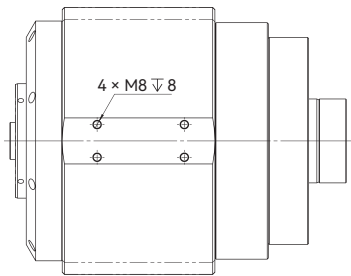

## ARH250

Specifications	Unit	ARH250
Diameter	mm	250
Center Height	mm	160
Max. Swivel Angle	/	N*360
Continuous Torque	Nm	150
Peak Torque	Nm	462
Max. Speed	rpm	200
Continuous Current	Arms	11
Peak Current	Arms	33.1
Clamping Mode	/	Pneumatic - Normally Closed
Clamping Torque	Nm	600 (0bar)
Accuracy	arcsec	8 (VDI)
Repeatability	arcsec	4 (VDI)
Max. Payload	Kg	120
Net Weight	Kg	≤140

### ■ Dimensional Drawing

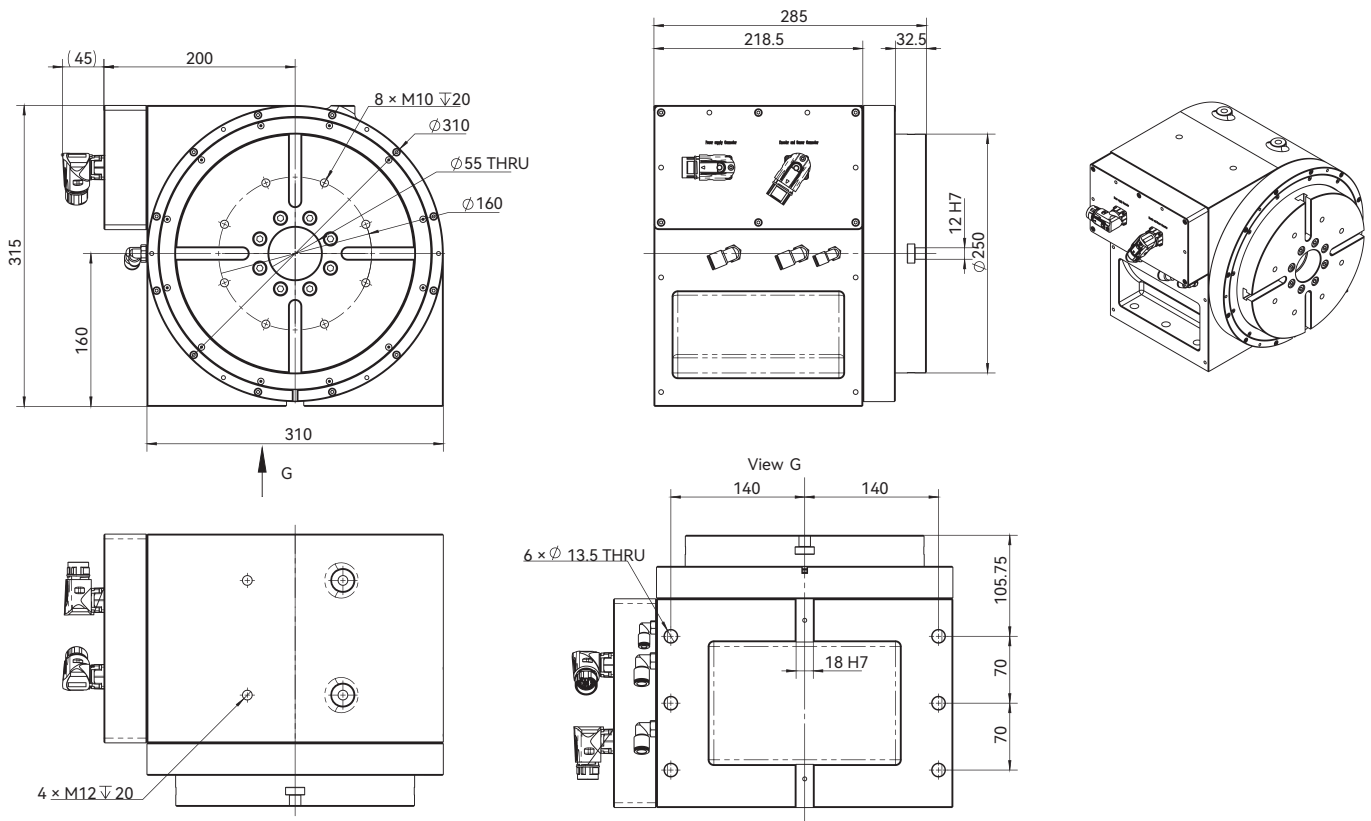

# ARH Series

## Ordering Part Number (OPN)

**ARH250B-160-B10A00-200KT-000**

Type:

ARH: Horizontal Turntable

Design Control Code:

000: Standard

Diameter:

105: Table diameter: 105mm  
250: Table diameter: 250mm

Thermal Sensor:

K: PT100  
KT: PT100+KTY84  
DE: PT1000+SNM(PTC)

Installation Feature:

B: Bottom mounting

Axis Height:

135: Axis height: 135mm  
150: Axis height: 150mm  
160: Axis height: 160mm

Max Speed:

200: Max speed: 200rpm

Encoder Protocols: ①

B: Biss-C  
S: SSI  
E: Endat2.2  
D: Drive-CLiQ

Cable: ②

00: Aviation sockets  
30: 3m Flying Leads  
40: 4m Flying Leads  
... ..  
90: 1m Flying Leads  
99: 1m Flying Leads

Accuracy: ②

5: Radial Runout: 0.005mm, Axial Runout: 0.005/300mm  
10: Radial Runout: 0.010mm, Axial Runout: 0.01/0300mm

Clamping:

A: Pneumatic clamping  
H: Hydraulic clamping  
X: No clamping

Note:

- ① For other agreements, please consult for customization.
- ② For higher precision, please consult for customization.
- ③ Please consult customization for cord outlet and plug.  
For more options, please consult [cust-serrice@akribis-sys.com](mailto:cust-serrice@akribis-sys.com)

# ARV Series Vertical CNC Turntable

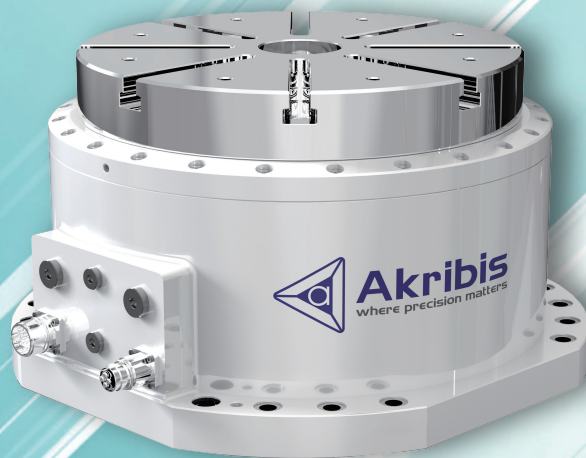

Direct drive technology, compact design

Fast dynamic response, wear-free, zero backlash

High torque density, high acceleration

High speed for continuous processing

Self-developed clamping system, supporting positioning and machining at any angle

High precision encoder compatible with various CNC systems

Applicable to vertical turning, vertical grinding, turning milling compound, universal grinder, etc

## ARV250

Specifications	Unit	ARV250
Diameter	mm	250
Height	mm	215
Max. Swivel Angle	/	N*360
Continuous Torque	Nm	300
Peak Torque	Nm	829
Max. Speed	rpm	110
Continuous Current	Arms	12
Peak Current	Arms	37.3
Clamping Mode	/	/
Clamping Torque	Nm	/
Accuracy	arcsec	8 (VDI)
Repeatability	arcsec	4 (VDI)
Max. Payload	Kg	240
Net Weight	Kg	≤85

### ■ Dimensional Drawing

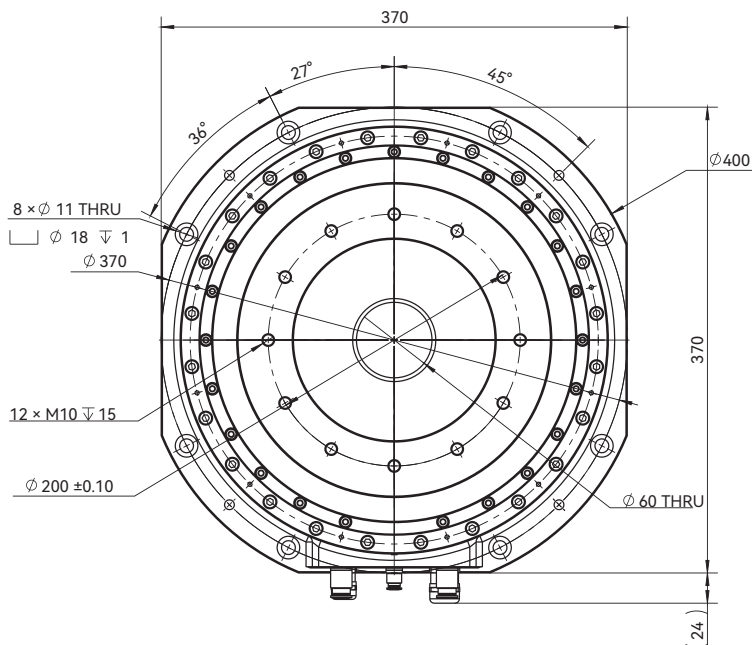
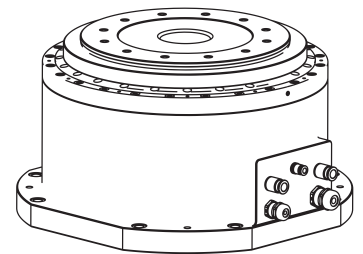
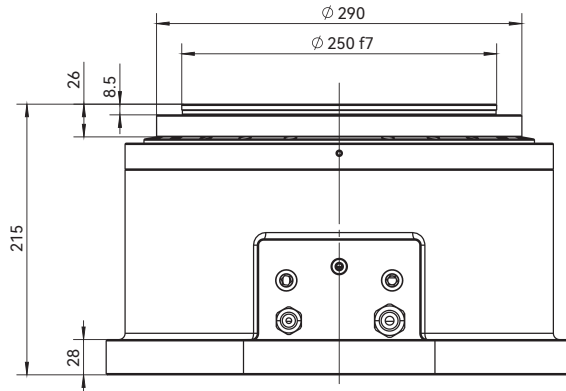

## ARV300

Specifications	Unit	ARV300
Diameter	mm	300
Height	mm	220
Max. Swivel Angle	/	N*360
Continuous Torque	Nm	180
Peak Torque	Nm	520
Max. Speed	rpm	110
Continuous Current	Arms	11.3
Peak Current	Arms	35.6
Clamping Mode	/	Hydraulic - Normally Open
Clamping Torque	Nm	650 (60bar)
Accuracy	arcsec	8 (VDI)
Repeatability	arcsec	4 (VDI)
Max. Payload	Kg	300
Net Weight	Kg	≤105

### ■ Dimensional Drawing

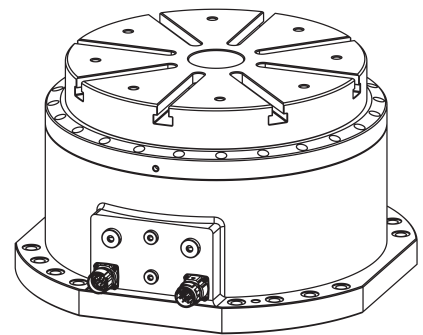
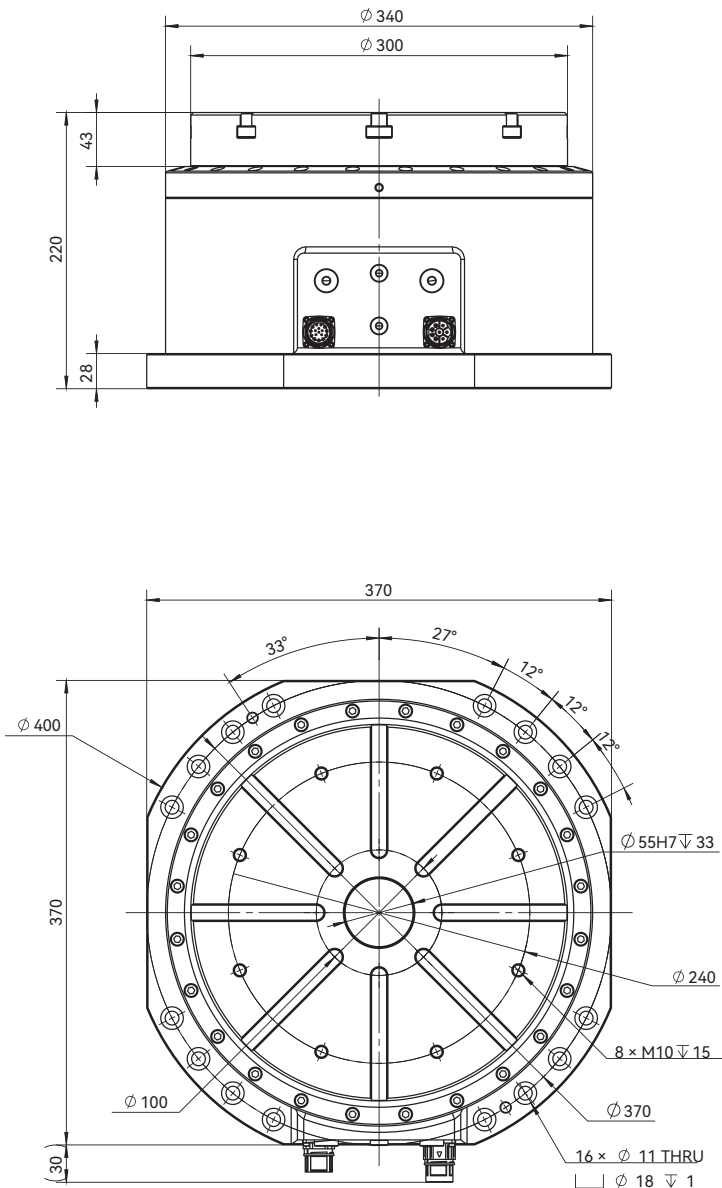



## Ordering Part Number (OPN)

**ARV300B-220-B10H00-100KT-000**

**Type:**

ARV: Vertical Turntable

**Design Control Code:**

000: Standard

**Diameter:**

250: Table diameter: 250 mm  
 300: Table diameter: 300 mm  
 400: Table diameter: 400 mm  
 630: Table diameter: 630 mm  
 800: Table diameter: 800 mm

**Thermal Sensor:**

K: PT100  
 KT: PT100+KTY84  
 DE: PT1000+SNM(PTC)

**Installation Feature:**

F: Bottom mounting  
 B: Flange mounting

**Max speed:**

100: Max speed: 100rpm

**Table height:**

220: Table height: 220mm  
 240: Table height: 240mm  
 330: Table height: 330mm  
 360: Table height: 360mm

**Cable:**

00: Aviation sockets  
 30: 3m Flying Leads  
 40: 4m Flying Leads  
 ... ..  
 90: 9m Flying Leads  
 99: 99m Flying Leads

**Encoder Protocols:**

B: Biss-C  
 S: SSI  
 E: Endat2.2  
 D: Drive-CLiQ

**Clamping:**

A: Pneumatic clamping  
 H: Hydraulic clamping  
 X: No clamping

**Accuracy:**

5: Radial Runout: 0.005mm, Axial Runout: 0.005/300mm  
 10: Radial Runout: 0.010mm, Axial Runout: 0.01/0300mm

**Note:**

- ❶ For other agreements, please consult for customization.
  - ❷ For higher precision, please consult for customization.
  - ❸ Please consult customization for cord outlet and plug.
- For more options, please consult [cust-service@akribis-sys.com](mailto:cust-service@akribis-sys.com)



## Manufacturing Facilities

### Akribis Systems Pte Ltd

56 Serangoon North Avenue 4  
 Singapore 555851  
 Tel: +65 6484 3357  
[www.akribis-sys.com](http://www.akribis-sys.com)  
[cust-service@akribis-sys.com](mailto:cust-service@akribis-sys.com)

### Akribis Systems (Shanghai) Co., Ltd

C4, No.6999, Chuan Sha Rd, Pudong New Area,  
 Shanghai, 201202  
 Tel: +86 21 5859 5800  
[www.akribis-sys.cn](http://www.akribis-sys.cn)  
[cust-service@akribis-sys.cn](mailto:cust-service@akribis-sys.cn)

### Akribis Systems (Nantong) Co., Ltd

Floor 2, Building 7, Boding Machinery,  
 Industrial Park, Xingyuan Road, Tongzhou,  
 Nantong, Jiangsu Province, 226000  
 Tel: +86 0513 8655 1333  
[www.akribis-sys.cn](http://www.akribis-sys.cn)  
[cust-service@akribis-sys.cn](mailto:cust-service@akribis-sys.cn)

### Akribis Systems Sdn Bhd (Selangor)

Lot 5815-A, Jalan Mawar, Taman Bukit  
 Serdang, Seksyen 9, 43300 Seri Kembangan,  
 Selangor D.E.  
 Tel: +603 8957 5815  
[www.akribis-sys.com](http://www.akribis-sys.com)  
[cust-service@akribis-sys.com](mailto:cust-service@akribis-sys.com)

### Akribis Systems (Shanghai) Co., Ltd Dongguan Branch

1F, Building B, No.12, Guliao 1st Road, Tianxin  
 Village, Tangxia Town, Dongguan City, Guangdong  
 Province, China, 523000  
 Tel: +86 0755 23777203  
[www.akribis-sys.cn](http://www.akribis-sys.cn)  
[cust-service@akribis-sys.cn](mailto:cust-service@akribis-sys.cn)

### Akribis Systems Korea Co., Ltd (Siheung)

1F/2F, 50, Maehwasandan 3-gil, Siheung-si,  
 Gyeonggi-do, Republic of Korea, 14931  
 Tel: +82 31 509 5033  
[www.akribis-sys.co.kr](http://www.akribis-sys.co.kr)  
[cust-service@akribis-sys.co.kr](mailto:cust-service@akribis-sys.co.kr)

## Branches

### Asia

#### Bangkok

Tel: +668 5151 0088  
[www.akribis-sys.com](http://www.akribis-sys.com)  
[bancha@akribis.co.th](mailto:bancha@akribis.co.th)

#### Hangzhou

Tel: +86 0571 86513821  
[www.akribis-sys.cn](http://www.akribis-sys.cn)  
[cust-service@akribis-sys.cn](mailto:cust-service@akribis-sys.cn)

#### Kfar-Saba

Tel: +972 9 8909797  
[www.agito-akribis.com](http://www.agito-akribis.com)  
[agito.info@akribis-sys.com](mailto:agito.info@akribis-sys.com)

#### Mumbai/Bangalore

Tel: +91 022 68629000  
[www.akribis-sys.com](http://www.akribis-sys.com)  
[cust-service@akribis-sys.com](mailto:cust-service@akribis-sys.com)

#### Penang

[www.akribis-sys.com](http://www.akribis-sys.com)  
[cust-service@akribis-sys.com](mailto:cust-service@akribis-sys.com)

### North America

#### Boston

[www.akribis-sys.com](http://www.akribis-sys.com)  
[cust-service@akribis-sys.com](mailto:cust-service@akribis-sys.com)

#### San Jose

Tel: +1 408 913 1300  
[www.akribis-sys.com](http://www.akribis-sys.com)  
[cust-service@akribis-sys.com](mailto:cust-service@akribis-sys.com)

### Europe

#### Erlangen

Tel: +49 9131 81179 0  
[www.akribis-sys.de](http://www.akribis-sys.de)  
[sales@akribis-sys.de](mailto:sales@akribis-sys.de)

#### Copyright Notice

© 2026 Akribis Systems Pte. Ltd.  
 All rights reserved. This work may not be reproduced or transmitted in any  
 form or by any means without written permission of Akribis Systems.

#### Disclaimer

This product documentation was accurate and reliable at the time of its release.  
 Akribis Systems reserves the right to change the specifications of the product  
 described in this manual without notice at any time.